

# 3A STEP-DOWN PWM CONVERTER

## FEATURES

- Operating Input Voltage From 4.5V to 24V
- 3.3V, 5V, 12V and Adjustable Output Version
- Adjustable Version Output Voltage Range, 1.2V to 24V  $\pm$  4% max Over Line and Load Regulation
- Available in TO-263-5, TO-220-5, TO-220B and TO-252-5 Package
- Requires Only 4 External Components.
- 150KHz Fixed Constant Frequency
- Low Power Standby Mode,  $I_Q$  Typically 80 $\mu$ A
- TTL Shutdown Capability.
- Output Overvoltage Protection
- Current Limit and Thermal Shutdown Protection.
- 3A Guaranteed Output Load Current

## GENERAL DESCRIPTION

The AIC1595 series are step-down monolithic PWM converters for delivering 3A at fixed voltages of 3.3V, 5.0V, 12V and using an external divider to adjust output voltage from 1.2V to 24V with excellent line and load regulation.

Switching frequency up to 150KHz is achievable thus allowing smaller-sized filter components. Internal current limit and thermal shutdown circuits provide protection from overloads. It also provides output overvoltage and short protection under fault conditions. The internal precise reference combined with voltage feedback loop provides optimum output voltage accuracy and fast load transient response.

## APPLICATIONS

- Fixed Voltage power supply for LCD Monitor and LCD TV
- On-Card Switching regulators
- Simple High Efficiency Step-down regulator

## TYPICAL APPLICATION CIRCUIT

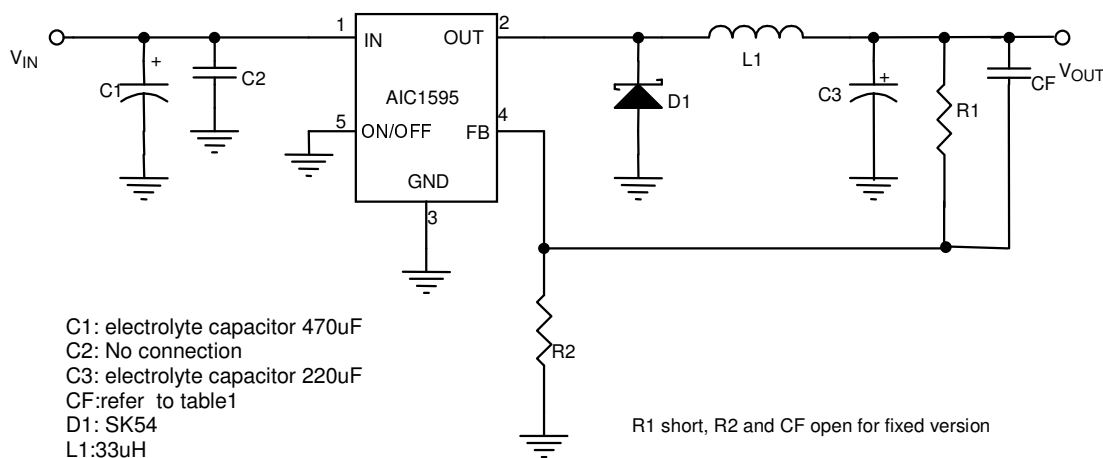

### 3A Precision PWM DC/DC Converter

## ORDERING INFORMATION

AIC1595-XXXXXXXX

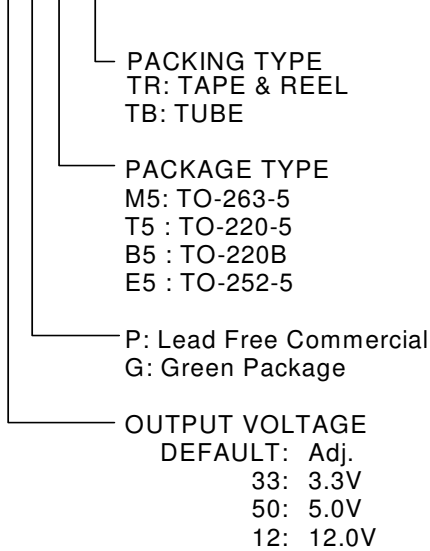

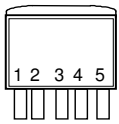
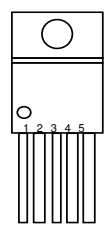
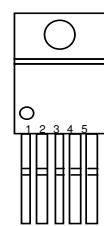
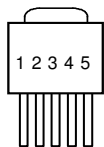
ORDER NUMBER	PIN CONFIGURATION
AIC1595PM5 AIC1595-33PM5 AIC1595-50PM5 AIC1595-12PM5	TO-263-5 FRONT VIEW 1: IN 2: OUT 3: GND 4: FB 5: ON/OFF 
AIC1595PT5 AIC1595-33PT5 AIC1595-50PT5 AIC1595-12PT5	TO-220-5 FRONT VIEW 1: IN 2: OUT 3: GND 4: FB 5: ON/OFF 
AIC1595PB5 AIC1595-33PB5 AIC1595-50PB5 AIC1595-12PB5	TO-220B FRONT VIEW 1: IN 2: OUT 3: GND 4: FB 5: ON/OFF 
AIC1595PE5 AIC1595-33PE5 AIC1595-50PE5 AIC1595-12PE5	TO-252-5 1: IN 2: OUT 3: GND 4: FB 5: ON/OFF 

Example: AIC1595-50PM5TR

→ 5.0V Output Version, in Lead Free TO-263-5 Package & Taping & Reel Packing Type

AIC1595-33PB5TR

→ 3.3V Output Version, in Lead Free TO-220B Package & Taping & Reel Packing Type

**■ ABSOLUTE MAXIMUM RATINGS**

Supply Voltage.....	24V
FB, ON/OFF Pin Input Voltage.....	-0.3V to 24V
Operating Temperature Range.....	-40°C ~ 85°C
Storage Temperature Range.....	-65°C ~ 150°C
Junction Temperature.....	125°C
Lead Temperature (Soldering 10s).....	260°C
Thermal Resistance Junction to Case	TO-263-5, TO-220-5, TO-220B.....3°C /W
	TO-252-5.....12.5°C /W
Thermal Resistance Junction to Ambient	TO-263-5.....60°C /W
(Assume no ambient airflow, no heatsink)	TO-220-5, TO-220B.....50°C /W
	TO-252-5.....100°C /W

**Absolute Maximum Ratings are those values beyond which the life of a device may be impaired.**

**■ TEST CIRCUIT**

Refer to Typical Application Circuit.

■ **ELECTRICAL CHARACTERISTICS** ( $T_A=25^{\circ}\text{C}$ ,  $V_{IN}=12\text{V}$  for the 3.3V, 5V and Adjustable version and  $V_{IN}=24\text{V}$  for the 12V version.) (Note1)

PARAMETER	TEST CONDITIONS	MIN.	TYP.	MAX.	UNIT
Input Voltage		4.5		24	V
Fixed Output Voltage	AIC1595-33 ( $V_{IN} > 4.75\text{V}$ )	3.168		3.432	V
	AIC1595-50 ( $V_{IN} > 7.0\text{V}$ )	4.800		5.200	V
	AIC1595-12 ( $V_{IN} > 15\text{V}$ )	11.52		12.48	V
FB Reference Voltage		1.193		1.267	V
Saturation Voltage			1.2	1.4	V
Output Voltage Regulation				4	%
Quiescent Current	Internal switch off		5	10	mA
Shutdown Quiescent Current	ON/OFF= 5V (OFF)		80	200	$\mu\text{A}$
FB bias current	$V_{FB}=1.3$		10	50	nA
Output leakage current	$V_{out}=-0.9$		2	30	mA
Logic Input High	(Regulator OFF)	2.0			V
Logic Input Low	(Regulator ON)			0.6	V
Oscillator Frequency		130	150	180	KHz
Output Current Limit		3.6		6.9	A
Over Voltage Protection			120		%
Maximum Duty Cycle		100			%
Minimum Duty Cycle			0		%
Efficiency	$V_o=5\text{V}$ , $I_o=3\text{A}$		80		%

**Note 1:** Specifications are production tested at  $T_A=25^{\circ}\text{C}$ . Specifications over the  $-40^{\circ}\text{C}$  to  $85^{\circ}\text{C}$  operating temperature range are assured by design, characterization and correlation with Statistical Quality Controls (SQC).

**TYPICAL PERFORMANCE CHARACTERISTICS**

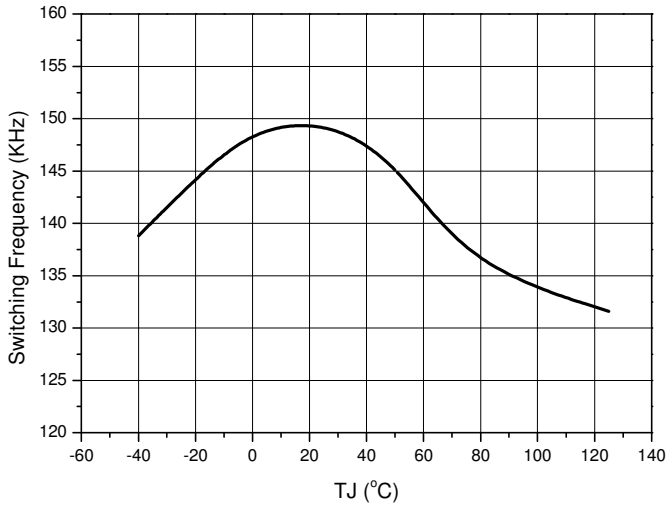

Fig.1 Switching Frequency vs. Temperature

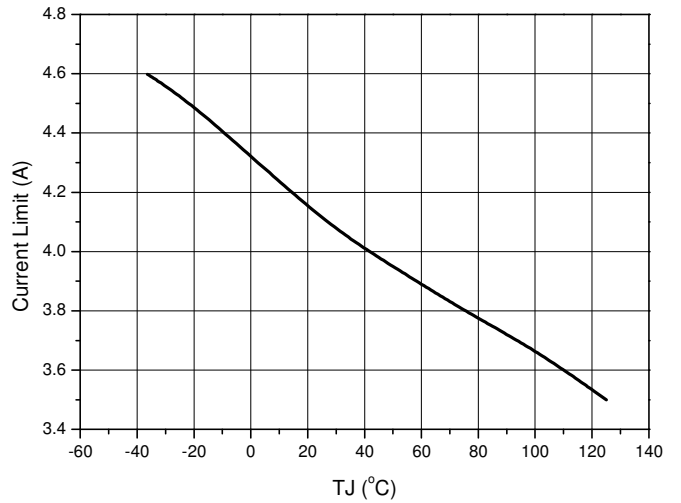

Fig.2 Current Limit vs. Temperature

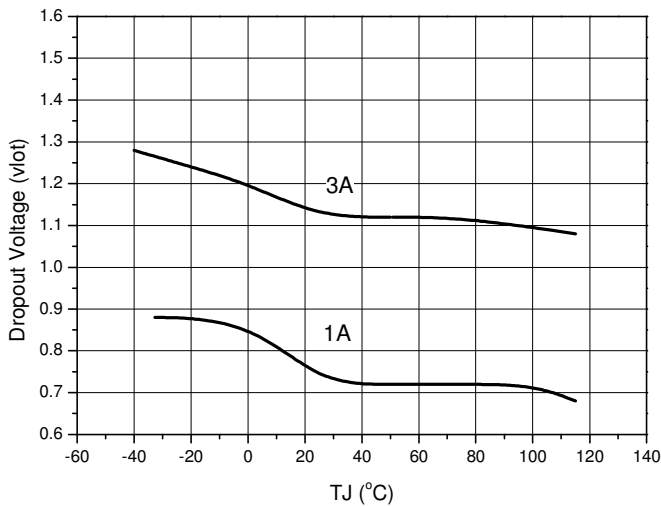

Fig.3 Dropout Voltage vs. Temperature

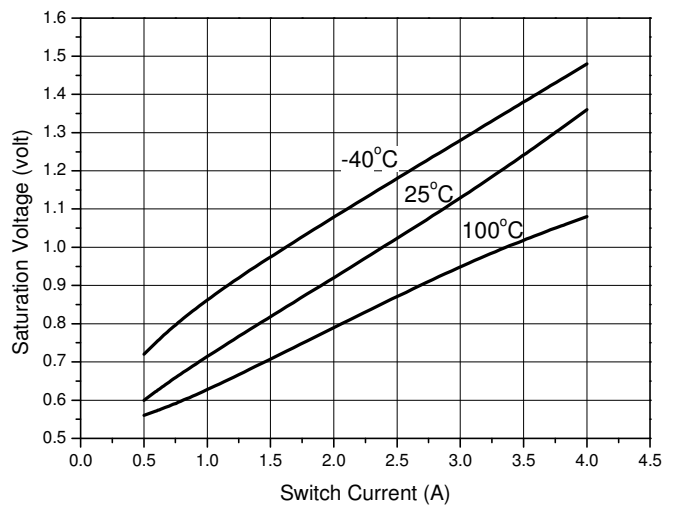

Fig.4 Switching Saturation Voltage vs. Switch Current

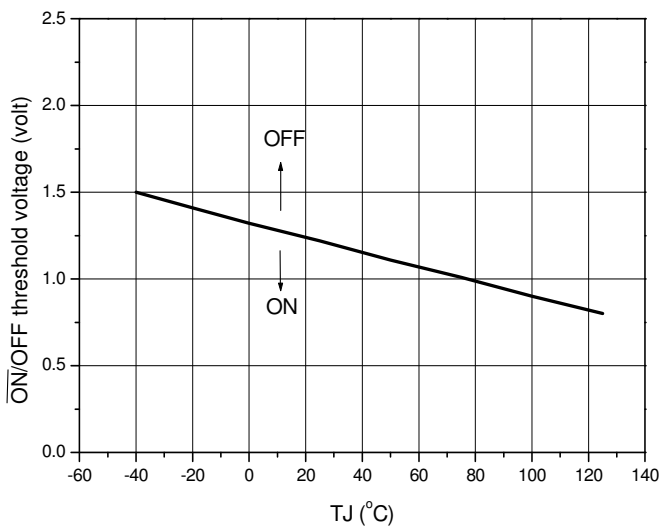

Fig.5 ON/OFF Threshold Voltage vs. Temperature

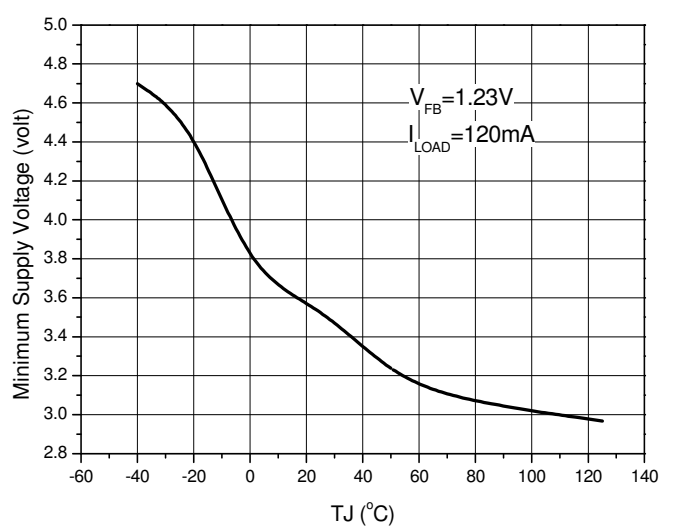

Fig.6 Minimum Operating Supply Voltage vs. Temperature (ADJ only)

**TYPICAL PERFORMANCE CHARACTERISTICS (Continued)**

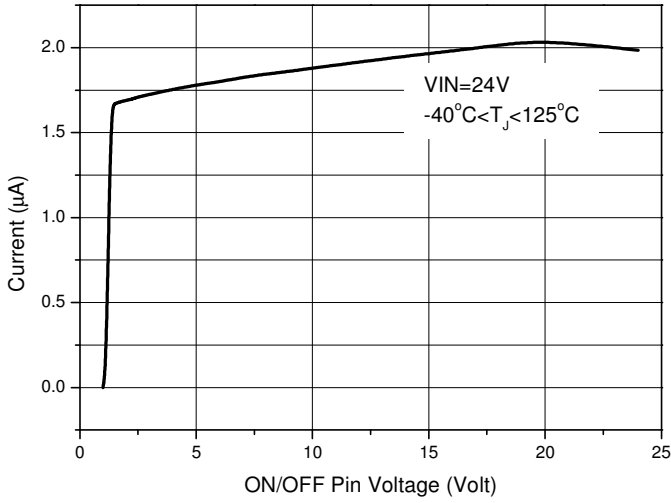

Fig.7 ON/OFF Pin Current (sinking) vs. Temperature

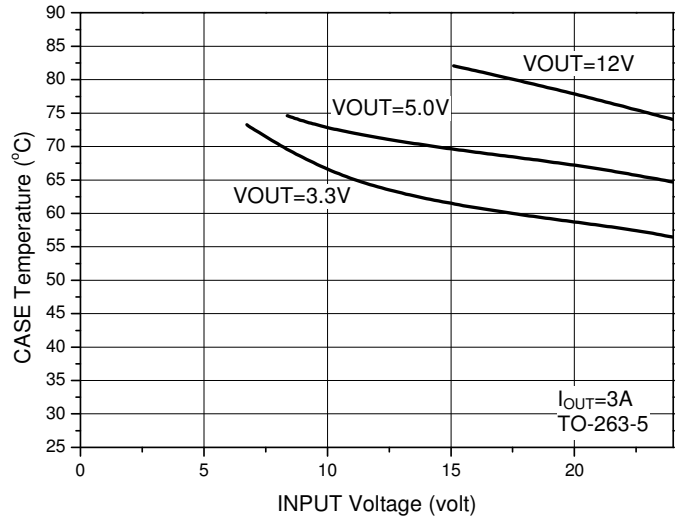

Fig.8 Case Temperature vs. Input Voltage

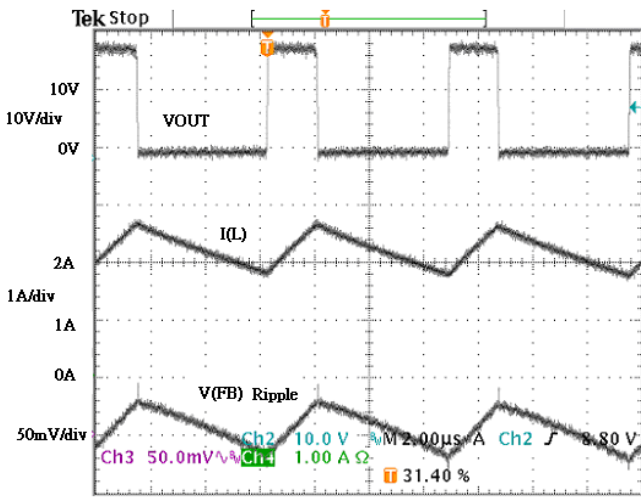

Fig.9 FB Pin Ripple(CCM)

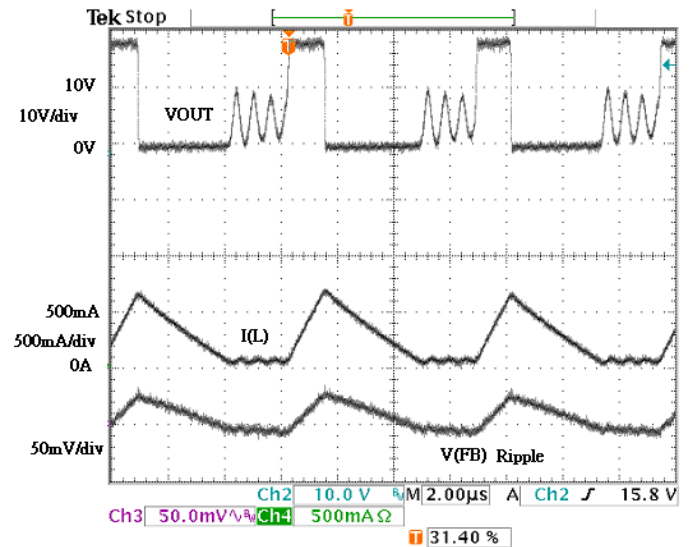

Fig.10 FB Pin Ripple(DCM)

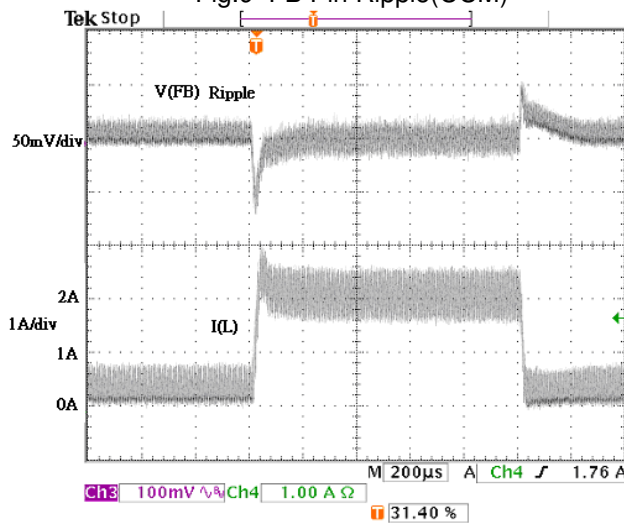

Fig.11 Load Transient Response

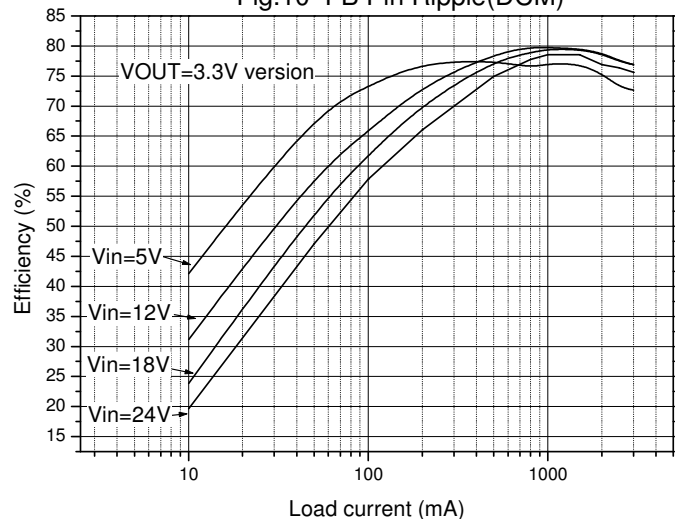

Fig.12 3.3V Version Efficiency

**TYPICAL PERFORMANCE CHARACTERISTICS (Continued)**

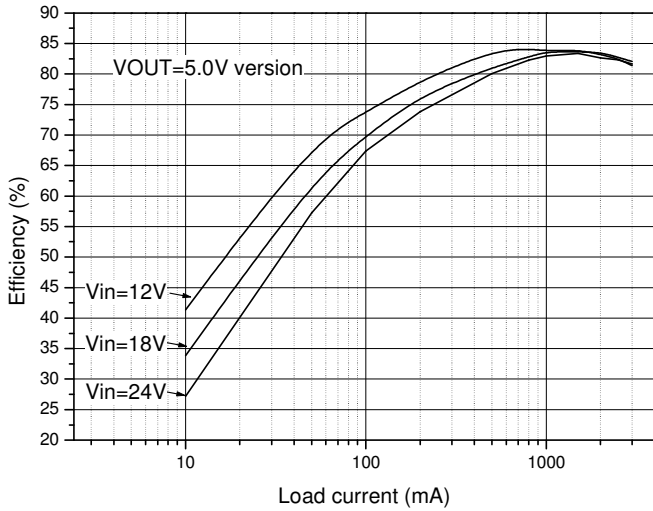

Fig.13 5V Version Efficiency

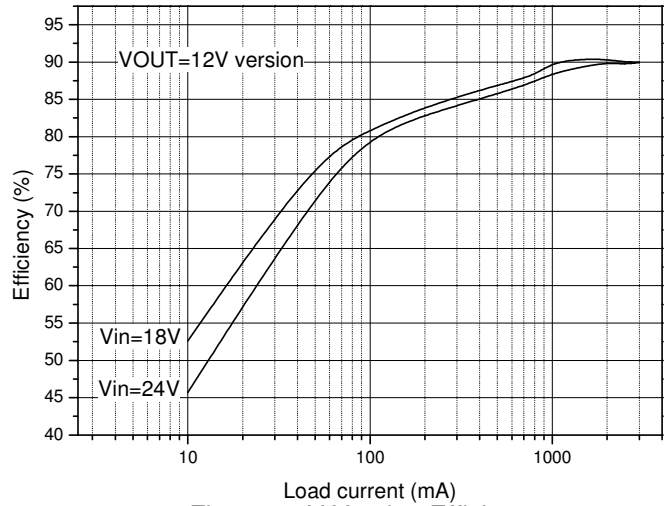
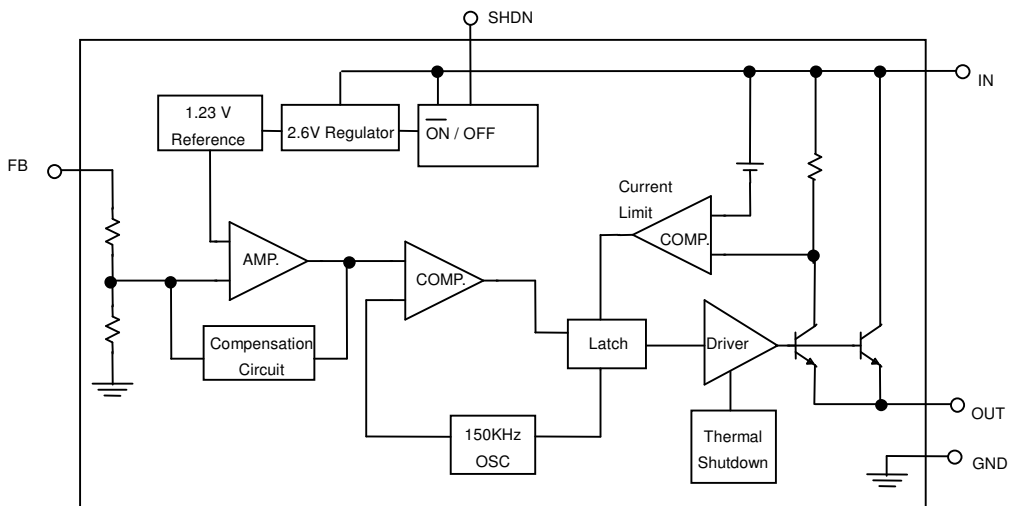

Fig.14 12V Version Efficiency

**BLOCK DIAGRAM**



## ■ PIN DESCRIPTIONS

- |            |   |                            |  |
|------------|---|----------------------------|--|
| PIN 1: IN  | Supply voltage input for the IC switching regulator. A suitable input bypass capacitor must be present at this pin to minimize voltage transients and to supply the switching currents needed by the regulator. | PIN 4: FB                  | Feedback input for fixed-output or adjustable-output version. Connect directly to output for fixed operation version or to a resistor divider for adjustable operation versions.   |
| PIN 2: OUT | Internal switch. The voltage at this pin switches between $(V_{IN}-V_{SAT})$ and approximately $-0.5V$ , with a duty cycle of approximately $V_{OUT}/V_{IN}$ .  | PIN 5: $\overline{ON}/OFF$ | Allows the switching regulator circuit to be shutdown using logic level signals thus dropping the total input supply current to approximately $80\mu A$ . Drive it high to disable the reference, control circuitry and internal switches. Drive low or connect to GND for normal operation. |
| PIN 3: GND | Ground requires a short, low noise connection to ensure good load regulation.   |                            |  |

## ■ APPLICATION INFORMATION

### Thermal considerations

The AIC1595 is available with TO-220-5, TO-220B, TO-263-5 and TO-252-5 packages. The TO-220-5 and TO-220B packages need a heat sink in most conditions. The TO-263-5 and TO-252-5 packages are designed to be soldered to the copper on a printed circuit board. The printed circuit board is the heat sink for TO-263-5 and TO-252-5 packages and other heat components, such as inductors and diodes. The size of the heat sink depends on the power loss of AIC1595 and the ambient temperature. The power loss of AIC1595 is determined by input voltage, output voltage and load current. The Fig.8 represents the curve of the AIC1595 case temperature in different conditions.

The curve shows the AIC1595 temperature rises above ambient temperature for a 3A load with different input and output voltage. The values of the temperature rise, which are affected by factors

such as sink size, heat produced from heat components, and etc., may be different from those in Fig.8 depending on the conditions of the application. According to the equation 1, as the power loss or ambient temperature is rising the heat sink size must be increased to decrease the thermal resistance ( $R\theta_{jA}$ ) so that the junction temperature does not over 125 C. An appropriate increase of heat sink size may result in a normal-ranged junction temperature.

$$P_D = \frac{T_j - T_A}{R\theta_{jA}} \text{-----(1)}$$

As junction temperature rises to its temperature protect point, the AIC1595 will stop working. Output voltage drops to zero until the junction temperature decreases to a normal range.



## ■ APPLICATION INFORMATION (Continued)

### Components Selection

#### Inductor

The inductor selection depends on the operating frequency of the AIC1595. The ripple current  $\Delta I_L$  interrelates with inductor value. A lower inductor value gets a higher ripple current. Besides, a higher  $V_{IN}$  or  $V_{OUT}$  can also get the same result. The inductor value can be calculated as the following formula.

$$L = \frac{1}{(f)(\Delta I_L)} V_{OUT} \left( 1 - \frac{V_{OUT}}{V_{IN}} \right) \text{-----(2)}$$

Users can define the acceptable  $\Delta I_L$  to gain a suitable inductor value.

#### Capacitor

The selection of output capacitor depends on the suitable ripple voltage. Lower ripple voltage corresponds to lower ESR (Equivalent Series Resistor) of output capacitor. Typically, once the ESR is satisfied with the ripple voltage, the value of capacitor is adequate for filtering. The formula of ripple voltage is as below:

$$\Delta V_{OUT} = \Delta I_L \left( ESR + \frac{1}{8fC_{OUT}} \right) \text{-----(3)}$$

The typical input capacitor is 470uF. But as the temperature decreases, the input capacitor needs to increase to stabilize the circuit.

#### Diode

The diode current rating must be higher than 1.3 times maximum load current. Also, if the power supply needs to resist a continuous output short, the diode should have a current rating equal to the maximum current limit of the AIC1595. The re-

verse voltage rating of the diode should be higher than 1.25 times input voltage and the diode must be fast. The reverse recovery time of the diode is short.

#### Example

Assume the input voltage is 12V, output voltage is 5V and maximum load current is 3A. The output ripple must be smaller than 2% of output voltage

Inductor selection

$$L = \frac{1}{(f)(\Delta I_L)} V_{OUT} \left( 1 - \frac{V_{OUT}}{V_{IN}} \right)$$

$$= \frac{1}{150k \times 0.6} \times 5 \times \left( 1 - \frac{5}{12} \right) = 32.4\mu H$$

Here, the delta  $I_L$  is 0.6A. So we choose 33uH inductor.

Output capacitor selection

$$\Delta V_{OUT} = \Delta I_L \left( ESR + \frac{1}{8fC_{OUT}} \right) < 100mV$$

We choice the capacitor value: ESR=0.12, capacitance=220uF

$$\Rightarrow \Delta V_{OUT} = \Delta I_L \left( ESR + \frac{1}{8fC_{OUT}} \right) = 74mV < 100mV$$

**The full load is 3A and delta  $I_L$  is 0.6A, so the diode current rating must be higher than 3.6A.**

#### CF Capacitor for adj version

As using the AIC1595 adj version, the CF capacitor is required to provide additional stability. In different condition, the CF capacitor must be

changed to make the circuit stable.

Output Voltage(V)	Input Voltage(V)	R1( $\Omega$ )	R2( $\Omega$ )	CF capacitor(F)
1.8	7	36k	82k	1000p
4	12	180k	82k	360p
6	12	180k	47k	360p
8	15	180k	33k	360p
10	18	150k	22k	470p
15	25	110k	10k	560p

Table 1

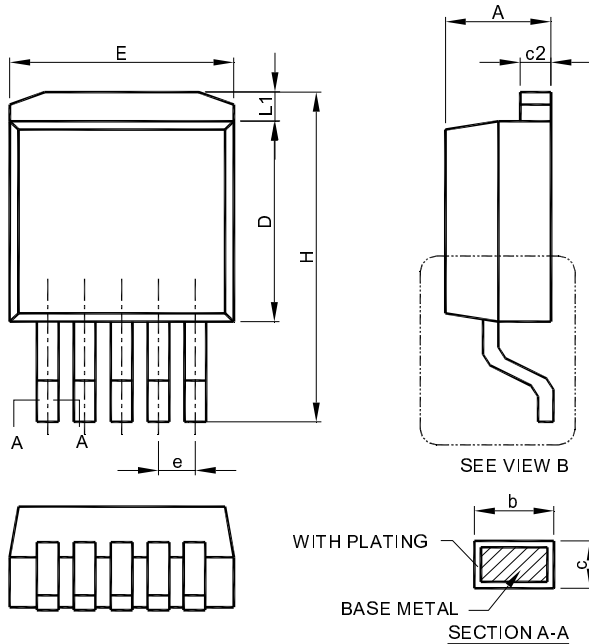
**PHYSICAL DIMENSIONS (unit: mm)**
**TO-263-5**

SYMBOL	TO-263-5L	
	MILLIMETERS	
	MIN.	MAX.
A	4.06	4.83
A1	0.00	0.25
b	0.51	0.99
c	0.38	0.74
c2	1.14	1.65
D	8.38	9.65
E	9.65	10.67
e	1.70 BSC	
H	14.61	15.88
L	1.78	2.79
L1	--	1.68
L3	0.25 BSC	
q	0°	8°

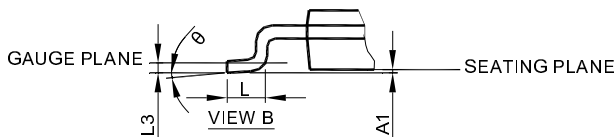

- Note: 1. Refer to JEDEC TO-263BA.  
 2. Dimension "E" does not include mold flash, protrusions or gate burrs. Mold flash, protrusion or gate burrs shall not exceed 6 mil per side.  
 3. Dimension "D" does not include inter-lead flash or protrusions.  
 4. Controlling dimension is millimeter, converted inch dimensions are not necessarily exact.

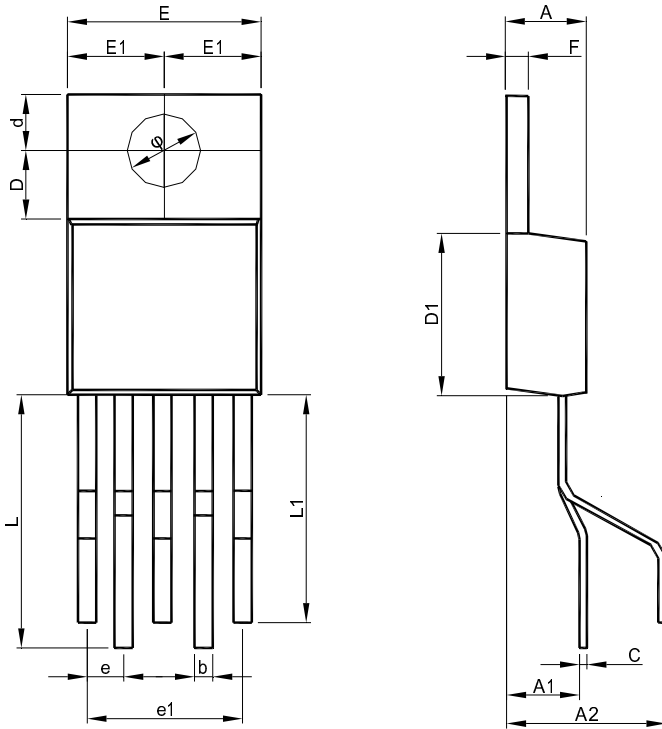
**■ PHYSICAL DIMENSIONS(Continued) (unit: mm)**
**● TO-220B**

SYMBOL	TO-220B	
	MILLIMETERS	
	MIN.	MAX.
A	4.318	4.826
A1	4.250	4.550
A2	8.250	8.550
b	0.690	0.940
C	0.304	0.530
D	3.556(REF)	
D1	8.480	9.300
d	2.743(REF)	
E	9.906	10.44
E1	4.953	5.220
∅	3.708	3.962
e	1.524	2.032
e1	6.604	7.112
F	1.143	1.397
L	9.880	10.64
L1	9.090	9.850

Note : Controlling dimension is millimeter, converted inch dimensions are not necessarily exact.

■ PHYSICAL DIMENSIONS(Continued) (unit: mm)

● TO-220-5L

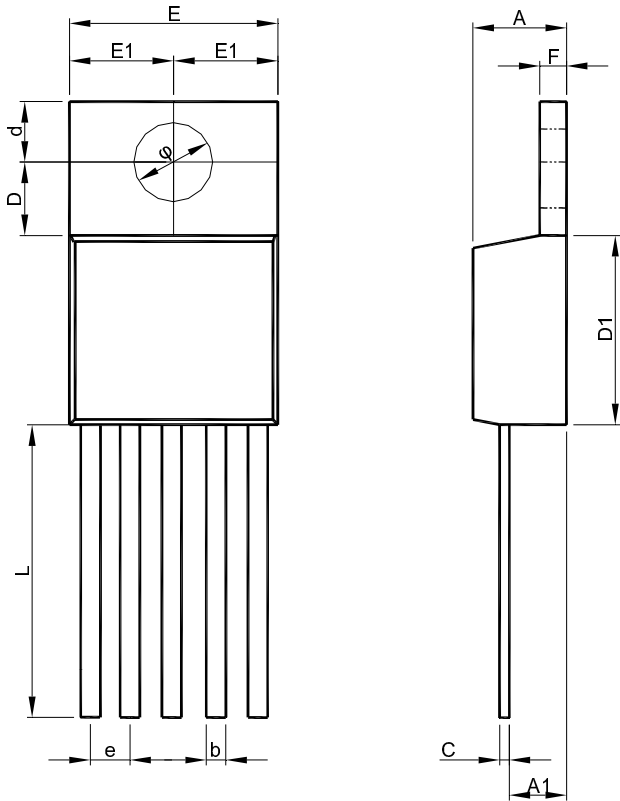

SYMBOL	TO-220-5L	
	MILLIMETERS	
	MIN.	MAX.
A	4.064	4.826
A1	2.032	2.921
b	0.635	1.016
C	0.304	0.460
D	3.429	3.683
D1	7.620	9.398
d	2.620	2.870
E	9.779	10.668
E1	4.953	5.220
Q	3.708	3.962
e	1.524	2.032
F	1.143	1.397
L	13.589	14.351

Note : Controlling dimension is millimeter, converted inch dimensions are not necessarily exact.

■ PHYSICAL DIMENSIONS(Continued) (unit: mm)

● TO-252-5

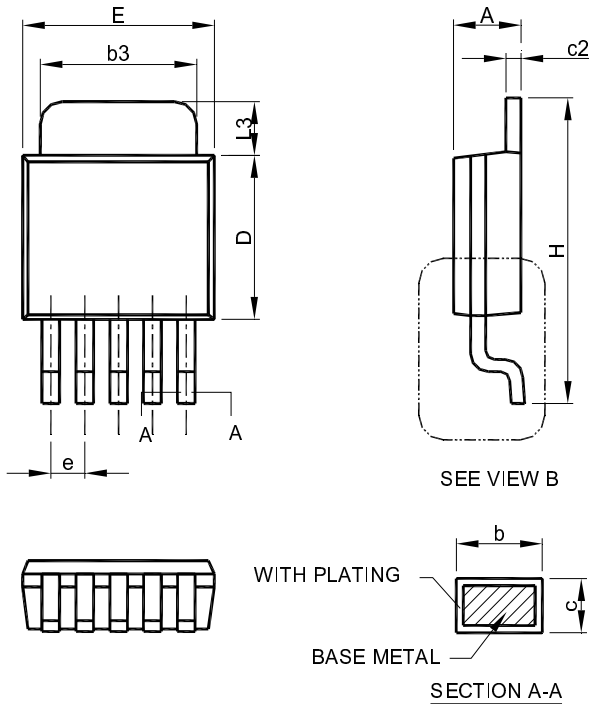

SYMBOL	TO-252-5L	
	MILLIMETERS	
	MIN.	MAX.
A	2.19	2.38
A1	0.00	0.13
b	0.51	0.71
b3	4.32	5.46
c	0.46	0.61
c2	0.46	0.89
D	5.33	6.22
E	6.35	6.73
e	1.27 BSC	
H	9.40	10.41
L	1.40	1.78
L1	2.67 REF	
L2	0.51 BSC	
L3	0.89	2.03
θ	0°	8°

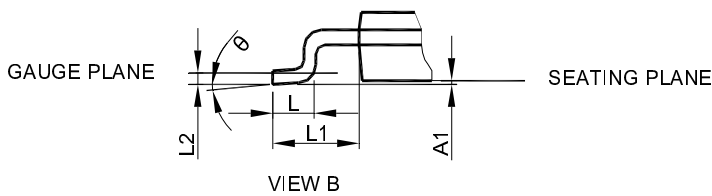

- Note: 1. Refer to JEDEC TO-252AD and AB.  
 2. Dimension "E" does not include mold flash, protrusions or gate burrs. Mold flash, protrusion or gate burrs shall not exceed 6 mil per side .  
 3. Dimension "D" does not include inter-lead flash or protrusions.  
 4. Controlling dimension is millimeter, converted inch dimensions are not necessarily exact.

**Note:**

Information provided by AIC is believed to be accurate and reliable. However, we cannot assume responsibility for use of any circuitry other than circuitry entirely embodied in an AIC product; nor for any infringement of patents or other rights of third parties that may result from its use. We reserve the right to change the circuitry and specifications without notice.

Life Support Policy: AIC does not authorize any AIC product for use in life support devices and/or systems. Life support devices or systems are devices or systems which, (i) are intended for surgical implant into the body or (ii) support or sustain life, and whose failure to perform, when properly used in accordance with instructions for use provided in the labeling, can be reasonably expected to result in a significant injury to the user.