

■ FEATURES

- Lowest Output Impedance (Typical 35Ω at $V_{IN}=5V$).
- Improved Direct Replacement for 7660.
- 1.5V to 6V Operation.
- No External Diode Required.
- Simple Conversion of +5V to -5V.
- Low Quiescent Current (Typical $36\mu A$ at $V_{IN}=5V$).
- High Power Efficiency (Typical 98%)
- Boost Pin for Higher Switching Frequency.
- Improved SCR Latch-up Protection.

■ APPLICATIONS

- RS-232 Power Supplies.
- Handheld Instruments.
- Data Acquisition Systems.
- Supply Splitter, $V_{OUT} = \pm V_{IN} / 2$.
- Operational Amplifier Supplies.
- Panel Meter.

■ TYPICAL APPLICATION CIRCUIT

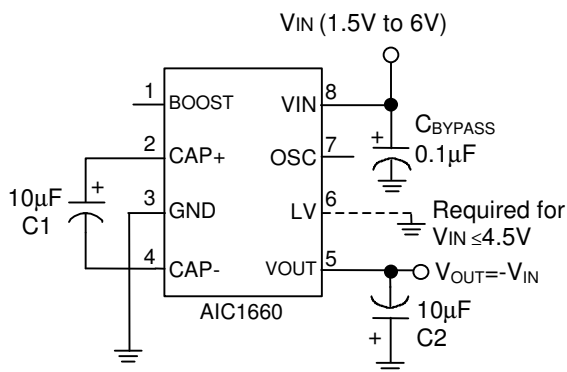

Negative Voltage Converter

■ DESCRIPTION

The AIC1660 is a monolithic CMOS switched capacitor voltage converter. Designed to be an improved direct replacement for the popular 7660 and LTC1044, the main function of the AIC1660 is to convert a positive input voltage in the range of 1.5V to 6V to the corresponding negative output voltage in the range of -1.5V to -6V. The input voltage can also be doubled ($V_{OUT} = 2V_{IN}$), divided ($V_{OUT} = V_{IN} / 2$), or multiplied ($V_{OUT} = \pm nV_{IN}$), as shown in application examples.

The chip contains a series DC power supply regulator, oscillator, control circuitry and four output power MOS switches. The frequency of oscillator can be lowered by the addition of an external capacitor to the OSC pin, or the oscillator may be over-driven by an external clock.

The boost function is available to raise the oscillator frequency to optimize performance in specific applications. The "LV" terminal may be tied to GND to improve low input voltage ($V_{IN} \leq 4.5V$) operation, or be left floating for input voltage larger than 4.5V to improve power dissipation.

The AIC1660 provides performance superior to previous designs by combining low output impedance, low quiescent current with high efficiency, and by eliminating diode drop voltage losses. The only required external components are two low cost electrolytic capacitors.

ORDERING INFORMATION

AIC1660XXXX

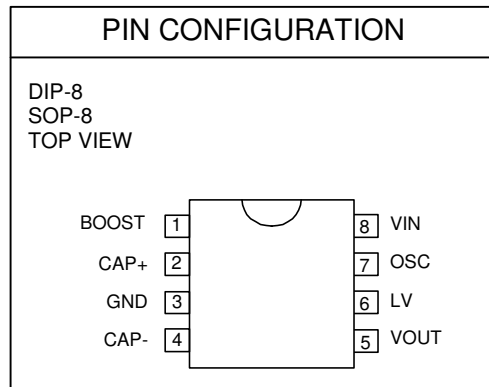
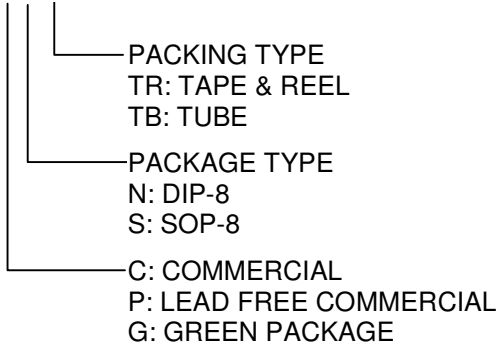

Example: AIC1660CSTR

→ in SOP-8 Package & Tape & Reel Packing Type
(DIP is not available in TR packing type.)

AIC1660PSTR

→ in Lead Free SOP-8 Package & Tape & Reel Packing Type

ABSOLUTE MAXIMUM RATINGS

Supply Voltage (VIN to GND, or GND to VOUT)	6.0V
Input Voltage on Pin 1, 6 and 7	-0.3V ~ VIN + 0.3V
Operating Temperature Range	-40°C ~ 85°C
Junction Temperature	125°C
Storage Temperature Range	-65°C ~ 150°C
Lead Temperature (Soldering, 10sec)	260°C
Thermal Resistance Junction to Case, RθJC	DIP-8	60°C /W
	SOP-8	40°C /W
Thermal Resistance Junction to Ambient, RθJA	DIP-8	100°C /W
(Assume no ambient airflow, no heatsink)	SOP-8	160°C /W

Absolute Maximum Ratings are those values beyond which the life of a device may be impaired.

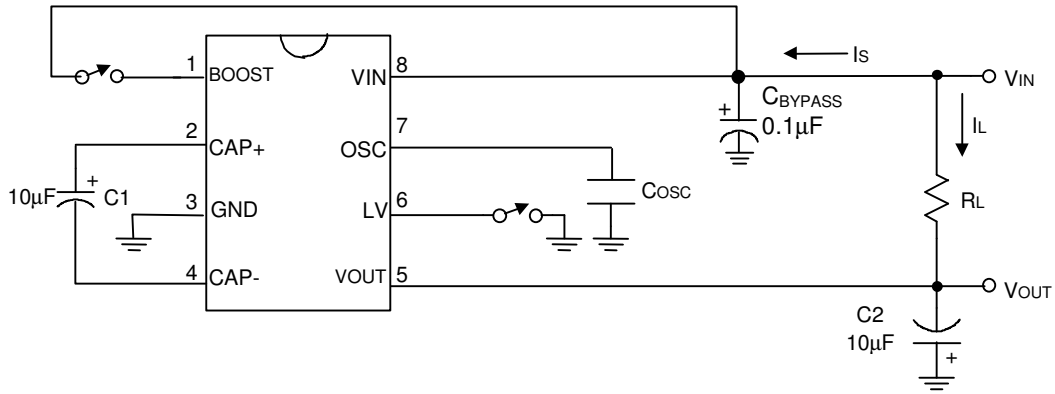
■ TEST CIRCUIT

■ ELECTRICAL CHARACTERISTICS

($V_{IN}=5.0V$, $T_A=25^{\circ}C$, $OSC=OPEN$, unless otherwise specified.) (Note 1)

PARAMETER	TEST CONDITIONS	SYMBOL	MIN	TYP	MAX	UNIT
Supply Current	$R_L = \infty$	I_S		36	70	μA
Minimum Supply Voltage	$R_L = \infty$	V_{INL}	1.5			V
Maximum Supply Voltage	$R_L = \infty$	V_{INH}			6	V
Output Resistance	$I_L = 20mA$, $F_{OSC} = 10KHz$	R_{OUT}		35	70	Ω
Oscillator Frequency	$C_{OSC} = 0$ Pin 1 Floating or GND Pin 1 = V_{IN}	F_{OSC}		10 50		KHz
Power Efficiency	$R_L = 5K$, $F_{OSC} = 10KHz$	η	96	98		%
Voltage Conversion Efficiency	$R_L = \infty$	V_{OUTEFF}	98	99.9		%

Note 1: Specifications are production tested at $T_A=25^{\circ}C$. Specifications over the $-40^{\circ}C$ to $85^{\circ}C$ operating temperature range are assured by design, characterization and correlation with Statistical Quality Controls (SQC).

■ TYPICAL PERFORMANCE CHARACTERISTICS

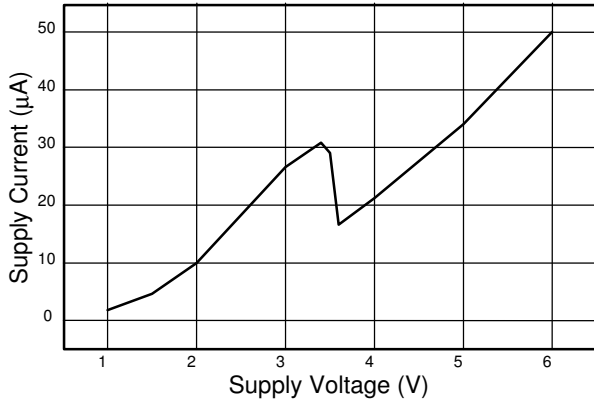

Fig. 1 Supply Current vs. Supply Voltage

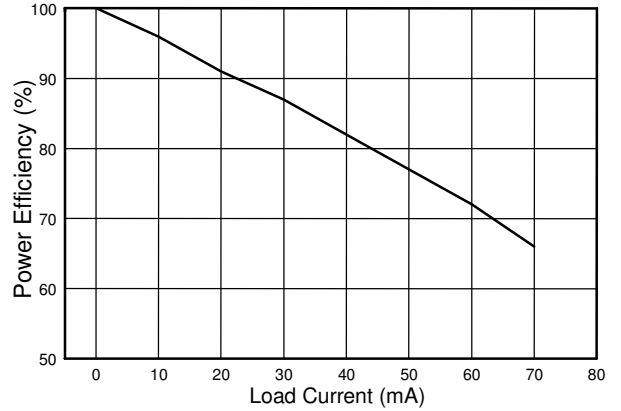

Fig. 2 Power Efficiency vs. Load Current

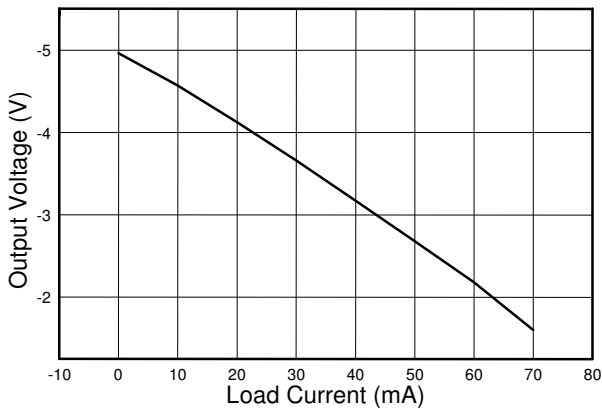

Fig. 3 Output Voltage vs. Load Current (VIN=5V)

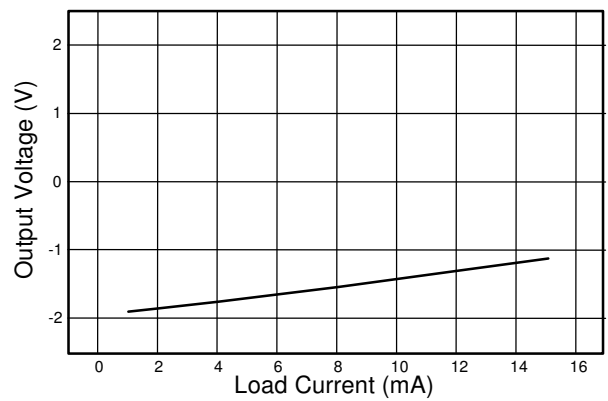

Fig. 4 Output Voltage vs. Load Current (VIN=2V)

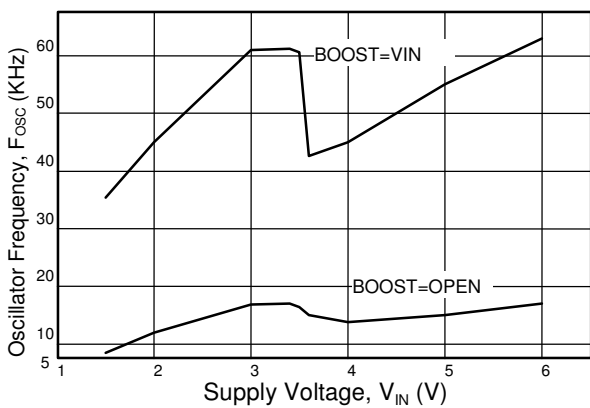

Fig. 5 Oscillator Frequency vs. Supply Voltage

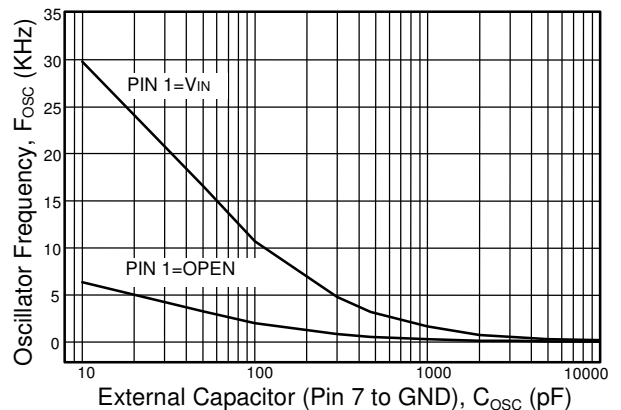

Fig. 6 Oscillator Frequency vs. Value of C_osc

■ **TYPICAL PERFORMANCE CHARACTERISTICS (Continued)**

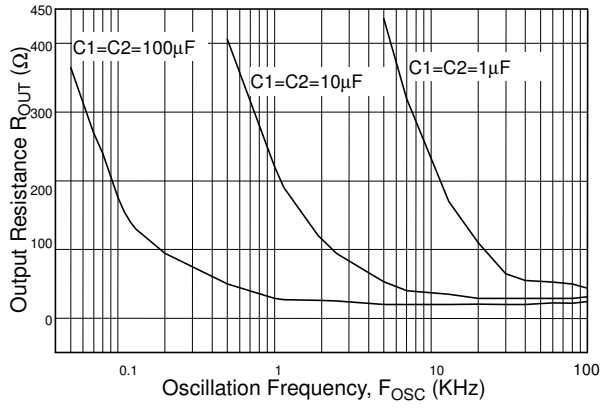
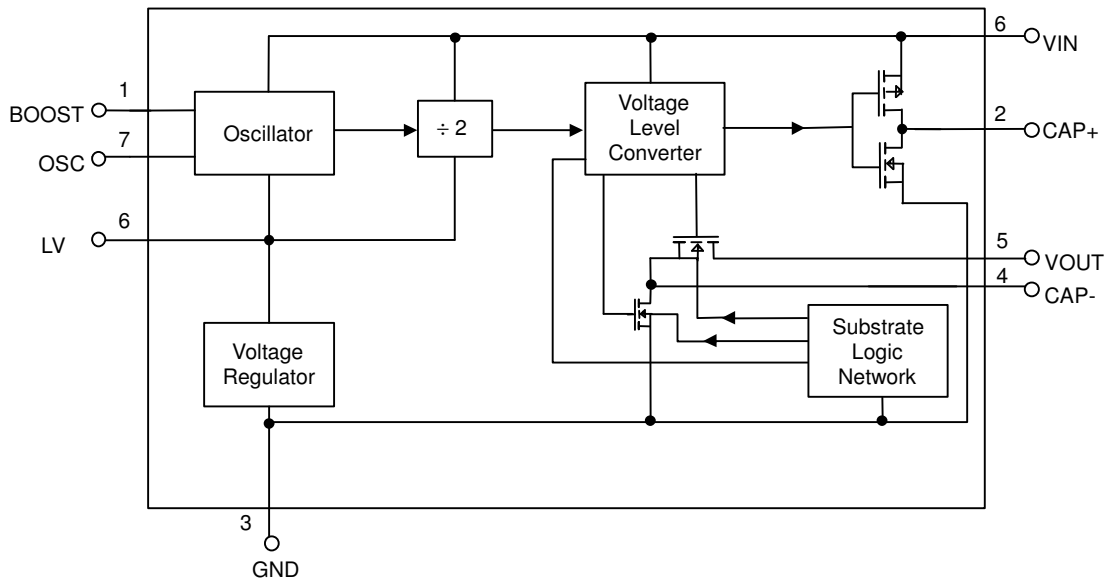

Fig. 7 Output Resistance vs. Oscillation Frequency

■ **BLOCK DIAGRAM**



■ PIN DESCRIPTIONS

- PIN 1: BOOST- The frequency of oscillator will be 5 times if boost pin is connected to V_{IN} .
- PIN 2: CAP+ - To be connected to the positive side of the flying capacitor.
- PIN 3: GND - Ground
- PIN 4: CAP- - To be connected to the negative side of flying capacitor.
- PIN 5: VOUT - Negative output voltage, typically connected to a $10\mu\text{F}$ capacitor.

- PIN 6: LV - If V_{IN} is below 4.5V, LV should be tied to GND. For V_{IN} greater than 4.5V, LV can be floating.
- PIN 7: OSC - The frequency of oscillator can be lowered by the addition of an external capacitor to the OSC pin. Or the oscillator may be over-driven by an external clock.
- PIN 8: VIN - Input supply.

■ APPLICATION EXAMPLES

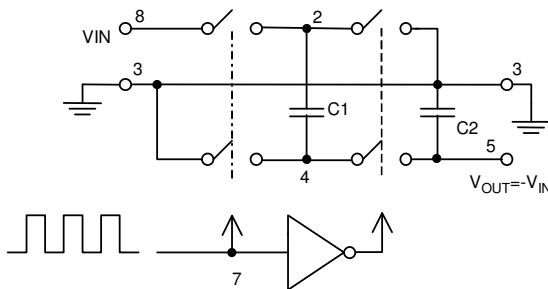

Fig. 8 Idealized Negative Voltage Converter

Fig. 8 shows the idealized negative voltage converter.

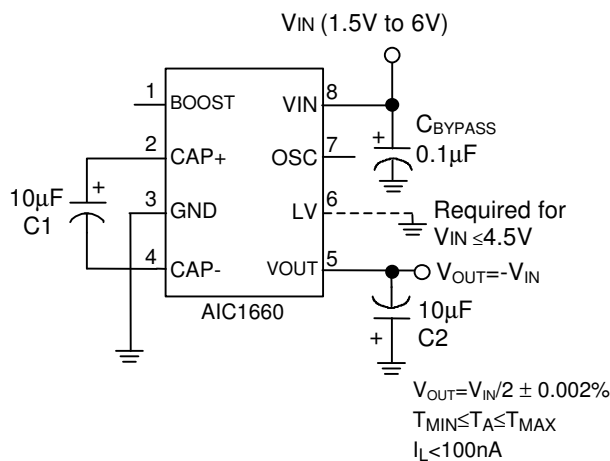

Fig. 9 Negative Voltage Converter

Fig. 9 shows a typical connection, which will provide a negative supply from an available positive supply without the need of any external diodes. The LV pin should be connect to ground for $V_{IN} \leq 4.5\text{V}$, or may be "floated" for $V_{IN} > 4.5\text{V}$.

■ APPLICATION EXAMPLES (Continued)

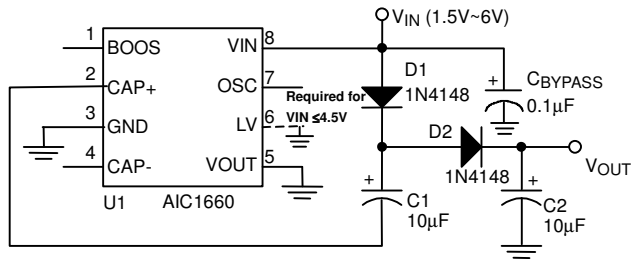

Fig. 10 Voltage Doubling

Fig. 10 shows a method of voltage doubling. $V_{OUT}=2V_{IN}-2V_D$. To reduce the voltage drops across diodes, use Schottky diodes.

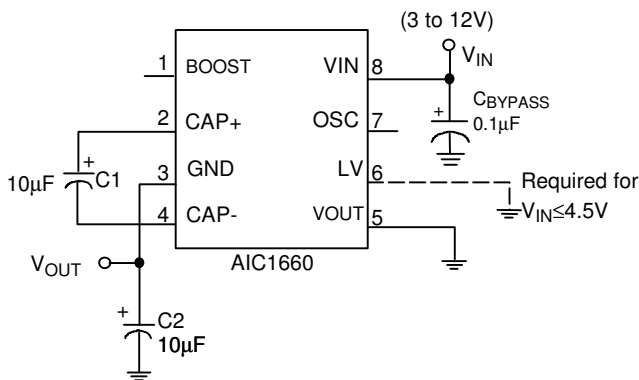

Fig. 11 Ultra Precision Voltage Divider

An ultra precision voltage divider is shown in Fig. 11. To achieve the 0.002% accuracy as indicated, the load current should be kept below 100nA. However, with a slight loss in accuracy, the load current can be increased.

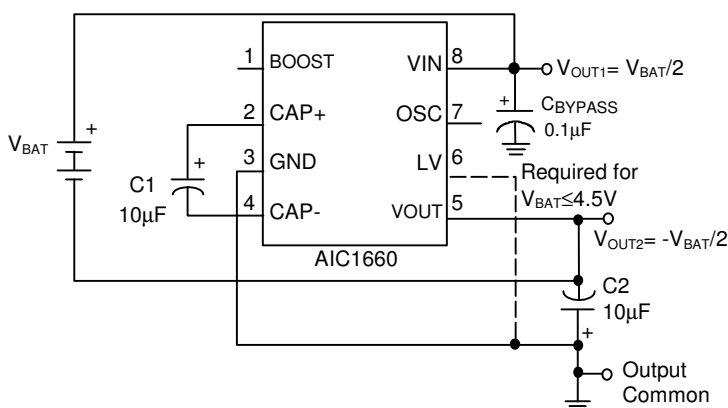
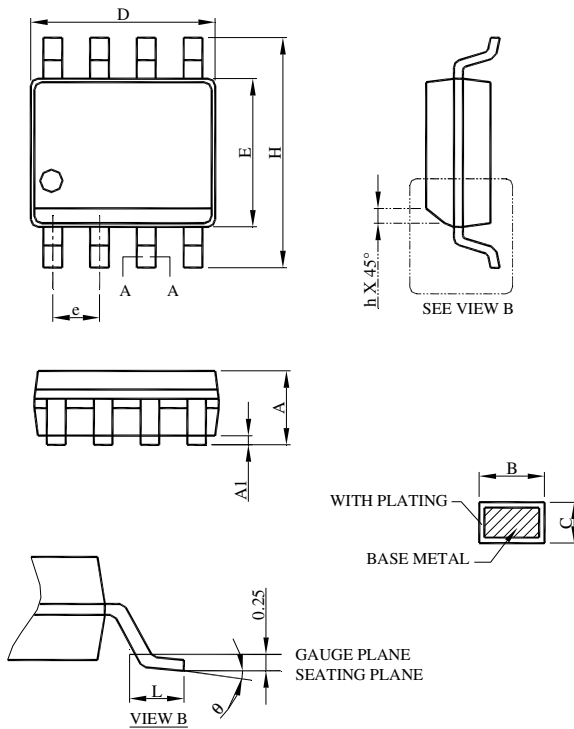

Fig. 12 Battery Splitter

A common need in many systems is to obtain (+) and (-) supplies from a single battery or power supply system. Where current requirements are low, the circuit shown in Fig. 12 is a simple solution.

■ PHYSICAL DIMENSIONS (unit: mm)
● SOP-8

SYMBOL	SOP-8	
	MILLIMETERS	
	MIN.	MAX.
A	1.35	1.75
A1	0.10	0.25
B	0.33	0.51
C	0.19	0.25
D	4.80	5.00
E	3.80	4.00
e	1.27 BSC	
H	5.80	6.20
h	0.25	0.50
L	0.40	1.27
θ	0°	8°

Note:

1. Refer to JEDEC MS-012AA.
2. Dimension "D" does not include mold flash, protrusions or gate burrs. Mold flash, protrusion or gate burrs shall not exceed 6 mil per side.
3. Dimension "E" does not include inter-lead flash or protrusions. Inter-lead flash or protrusion shall not exceed 10 mil per side.
4. Controlling dimension is millimeter, converted inch dimensions are not necessarily exact.

● DIP-8

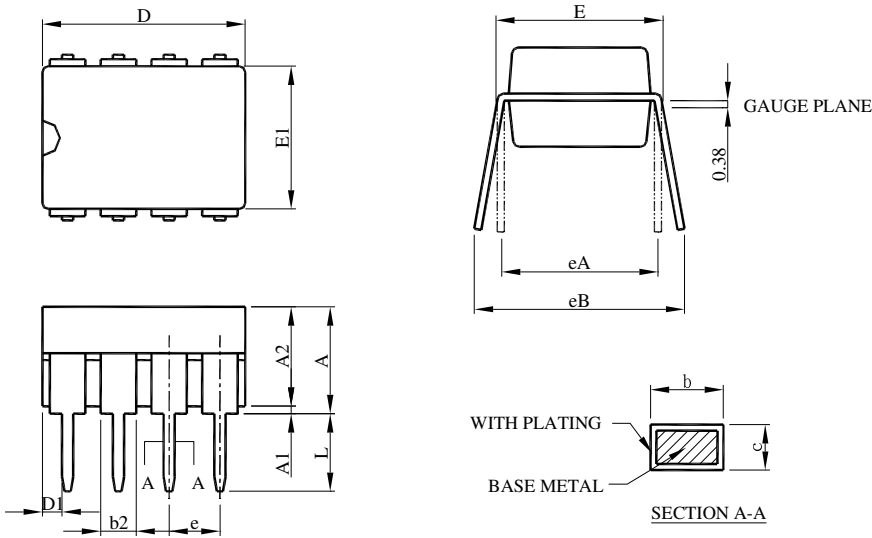

SYMBOL	DIP-8	
	MILLIMETERS	
	MIN.	MAX.
A		5.33
A1	0.38	
A2	2.92	4.95
b	0.36	0.56
b2	1.14	1.78
c	0.20	0.35
D	9.01	10.16
D1	0.13	
E	7.62	8.26
E1	6.10	7.11
e	2.54 BSC	
eA	7.62 BSC	
eB		10.92
L	2.92	3.81

Note:

1. Refer to JEDEC MS-001BA.
2. Dimension D, D1 and E1 do not include mold flash or protrusions. Mold flash or protrusion shall not exceed 10 mil.
3. Controlling dimension is millimeter, converted inch dimensions are not necessarily exact.

Note:

Information provided by AIC is believed to be accurate and reliable. However, we cannot assume responsibility for use of any circuitry other than circuitry entirely embodied in an AIC product; nor for any infringement of patents or other rights of third parties that may result from its use. We reserve the right to change the circuitry and specifications without notice.

Life Support Policy: AIC does not authorize any AIC product for use in life support devices and/or systems. Life support devices or systems are devices or systems which, (i) are intended for surgical implant into the body or (ii) support or sustain life, and whose failure to perform, when properly used in accordance with instructions for use provided in the labeling, can be reasonably expected to result in a significant injury to the user.