

350mA, 3 μ A Ultra Low Quiescent Current LDO Voltage Regulator

FEATURES

- Input Voltage 2.0V~6.8V
- Output Voltage 0.8V~5.0V
- 550mV Typical Dropout Voltage at 350mA load current and 3.3V output voltage
- Ultra Low Quiescent Current: 3 μ A
- Line Regulation, typical: 2mV
- Load Regulation, typical: 2mV
- Current Limiting and Thermal Protection
- Stable with 1 μ F Input & Output Ceramic Capacitor
- Available in SOT-23, SOT-23-5, SOT-89, DFN-6 2mmx2mm

GENERAL DESCRIPTION

The AIC1702 is an Ultra Low Quiescent Current, low dropout voltage regulator. The output voltages are of 0.8V, 1.0V, 1.2V, 1.5V, 1.8V, 2.0V, 2.5V, 3.3V and 5V. Dropout voltage of 200mV is guaranteed at 350mA output current and 3.3V output voltage. The low quiescent and wide input voltage range make this device ideal for portable microprocessor applications.

The AIC1702 requires output ceramic capacitor of a minimum 1 μ F for stability. Built-in output current limiting and thermal limiting provide maximal protection to the AIC1702 against fault conditions.

APPLICATIONS

- Smoke Detectors
- Battery-Powered Alarms / Smart Battery Packs
- PDAs / Handy Terminals
- Real-time Clocks/ CMOS Backup Pow
- Laptop, Palmtops, Notebook Computer

TYPICAL APPLICATION CIRCUIT

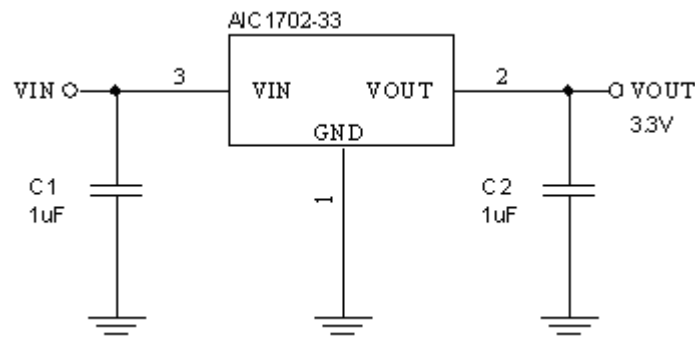

■ ORDERING INFORMATION

AIC1702-XX X XX XX

PACKING TYPE
 TR: TAPE & REEL
 BG: BAG

PACKAGE TYPE
 U3: SOT-23
 X3: SOT-89
 DA: DFN-6 (2*2)

G: Green Package

OUTPUT VOLTAGE

- 08: 0.8V
- 10: 1.0V
- 12: 1.2V
- 15: 1.5V
- 18: 1.8V
- 20: 2.0V
- 25: 2.5V
- 33: 3.3V
- 50: 5.0V

(Of a unit of 0.1V within 0.8~5.0V, additional voltage versions are available on demand)

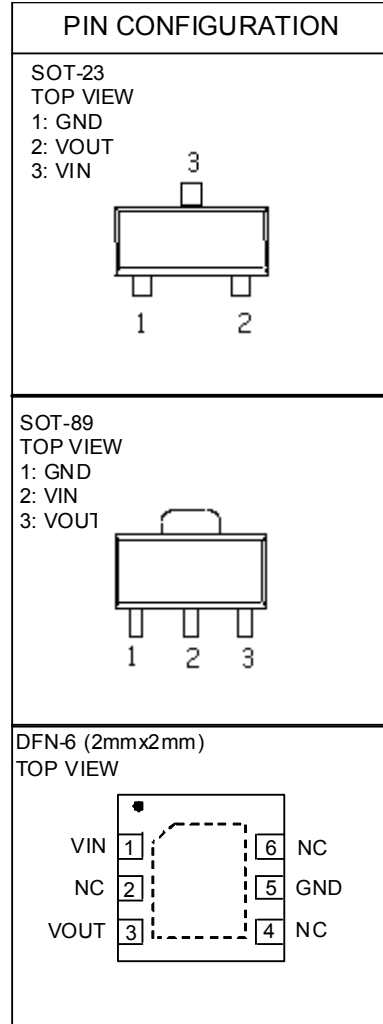

Example : AIC1702-18GU3TR
 → 1.8V Output Voltage,
 Green SOT-23 Package
 Tape & Reel Packing Type

AIC1702X-XX X XX XX

PACKING TYPE
 TR: TAPE & REEL
 BG: BAG

PACKAGE TYPE
 V5: SOT-23-5

G: Green Package

OUTPUT VOLTAGE

08:	0.8V
10:	1.0V
12:	1.2V
15:	1.5V
18:	1.8V
20:	2.0V
25:	2.5V
33:	3.3V
50:	5.0V

(Of a unit of 0.1V within
 0.8~5.0V, additional
 voltage versions are
 available on demand)

ENABLE TYPE

L: Chip Enable Low
 H: Chip Enable High

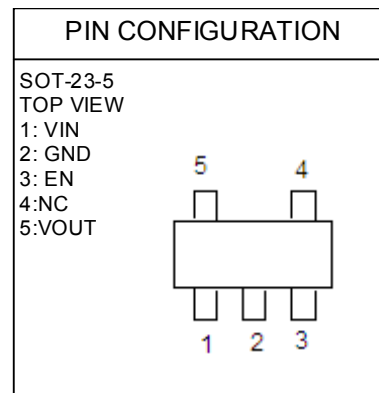

Example : AIC1702H-18GV5TR

- 1.8V Output Voltage,
- Chip Enable High
- Green SOT-23-5 Package
- Tape & Reel Packing Type

■ ABSOLUTE MAXIMUM RATINGS

Input Voltage	7V
EN Pin Voltage	7V
Operating Temperature Range	-40°C~85°C
Maximum Junction Temperature	150°C
Storage Temperature Range	-65°C~150°C
Lead Temperature (Soldering, 10 sec)	260°C
Thermal Resistance (Junction to Case) SOT-23	115°C /W
SOT-89	45°C /W
DFN-6	30°C /W
Thermal Resistance (Junction to Ambient) SOT-23	250°C /W
(Assume no ambient airflow, no heat sink) SOT-89	160°C /W
DFN-6	165°C /W

Absolute Maximum Ratings are those values beyond which the life of a device may be impaired.

■ **ELECTRICAL CHARACTERISTICS** ($V_{IN}=V_{OUT}+1V$, $C_{IN}=C_{OUT}=1\mu F$, $T_A=25^\circ C$, unless otherwise specified.) (Note1)

PARAMETER	CONDITIONS	SYMBOL	MIN.	TYP.	MAX.	UNITS
Operating Voltage		V_{IN}	2.0		6.8	V
Output Voltage Accuracy	$V_{OUT} \geq 1.0V$, $V_{IN} = V_{OUT} + 1.0V$ $V_{OUT} < 1.0V$, $V_{IN} = 2.0V$	V_{OUT}	-2.0		+2.0	%
Line Regulation	$I_{OUT} = 1mA$, (Note2)	ΔV_{LIR}		2	15	mV
Load Regulation	$I_{OUT}=1mA\sim 350mA$	ΔV_{LOR}		2	20	mV
Dropout Voltage	$V_{OUT} = 3.3V$, $I_{OUT}=350mA$	V_{DROP}		550		mV
Current Limit	$V_{OUT} \geq 1.5V$, $V_{IN} = V_{OUT} + 1.0V$	I_{IL}	400	500		mA
	$V_{OUT} < 1.5V$, $V_{IN} = 2.5V$	I_{IL}	350			mA
Short Circuit Current	$V_{OUT} = 0V$ (Note 3)	I_{SHORT}		350		mA
Output Voltage Temperature Coefficient	$-40^\circ C \leq T_A \leq 125^\circ C$	TC		100		ppm/ $^\circ C$
GND Pin Current	$I_{OUT}=1mA$	I_{GND}		3	6	μA
	$I_{OUT}=350mA$ (Note 3)			3	6	μA
Shutdown Standby Current	$V_{EN}=0$ or $V_{EN}^- = V_{IN}$	I_{STBY}			0.2	μA
Ripple Rejection	$F=1kHz$, $C_{OUT}=1\mu F$	PSRR		40		dB
Shutdown Pin Current	$V_{EN} = V_{IN} \leq 6.8V$ or GND	I_{EN}		0	100	nA
Shutdown Exit Delay Time	$I_{OUT} = 30mA$	Δt		0.5		mS
Max Output Discharge Resistance to GND during Shutdown		RDSON_C LMP		20	40	Ω
V_{EN} threshold	High threshold	V_{ENH}	1.6			V
	Low threshold	V_{ENL}			0.4	V
Thermal Shutdown Temperature		T_{SD}		135		$^\circ C$
Thermal Shutdown Hysteresis		ΔT_{SD}		25		$^\circ C$

Note 1: Specifications are production tested at $T_A=25^\circ C$. Specifications over the $-40^\circ C$ to $85^\circ C$ operating temperature range are assured by design, characterization and correlation with Statistical Quality Controls (SQC).

Note 2: $V_{OUT} \geq 1.0V$, $V_{IN} = V_{OUT} + 1.0V$ to 6.8V
 $V_{OUT} < 1.0V$, $V_{IN} = 2.0V$ to 6.8V

Note 3: $V_{OUT} \geq 1.5V$, $V_{IN} = V_{OUT} + 1.0V$
 $V_{OUT} < 1.5V$, $V_{IN} = 2.5V$

TYPICAL PERFORMANCE CHARACTERISTICS

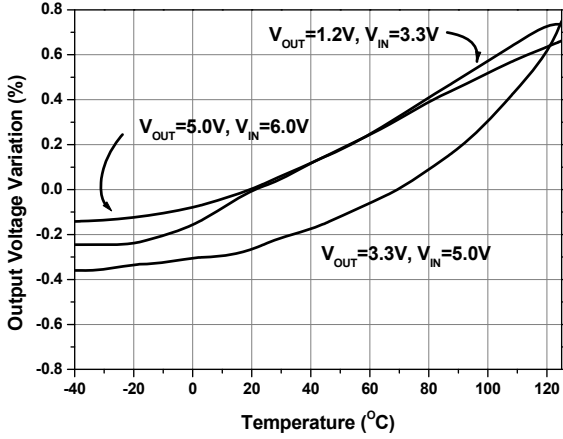

Fig.1 Output Voltage Variation vs. Temperature

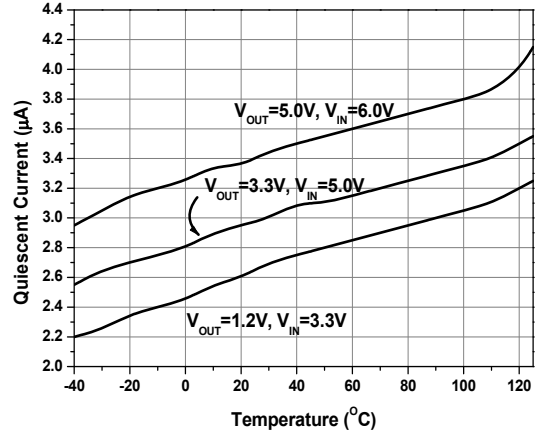

Fig.2 Quiescent Current vs. Temperature

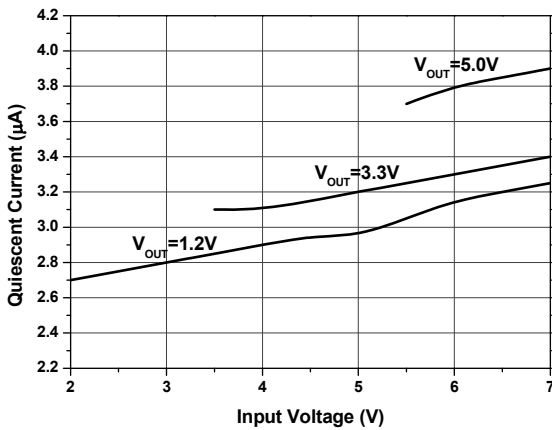

Fig.3 Quiescent Current vs. Input Voltage

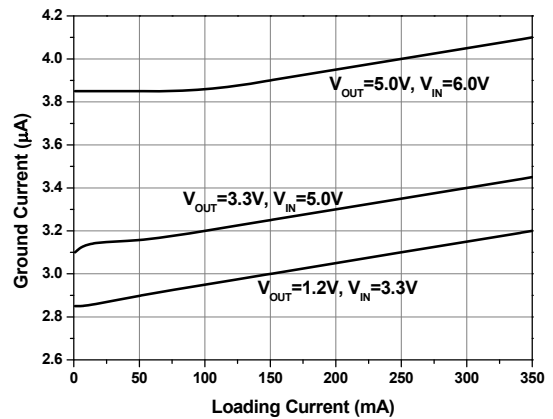

Fig.4 Ground Current vs. Loading Current

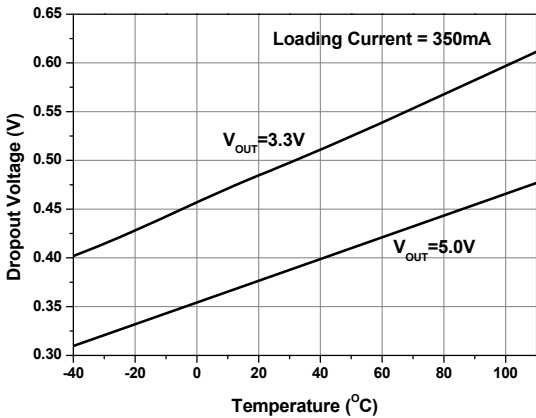

Fig.5 Dropout Voltage vs. Temperature

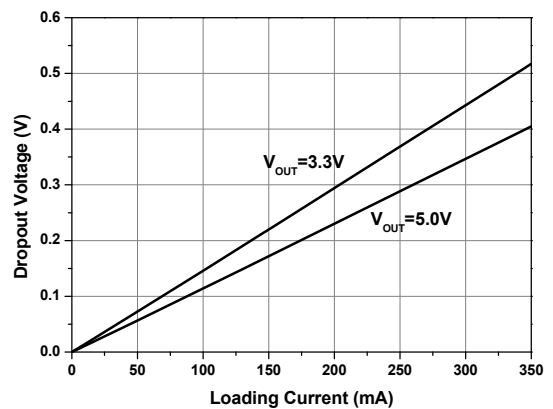

Fig.6 Dropout Voltage vs. Loading Current

TYPICAL PERFORMANCE CHARACTERISTICS (Continued)

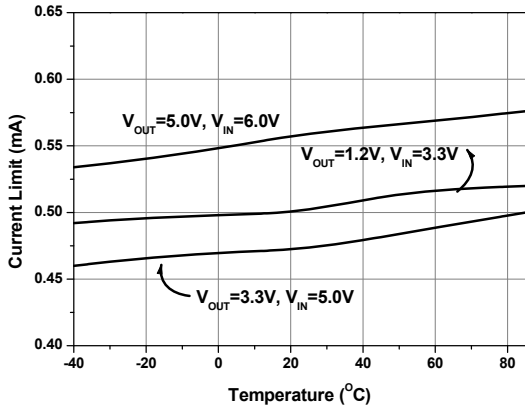

Fig.7 Current Limit vs. Temperature

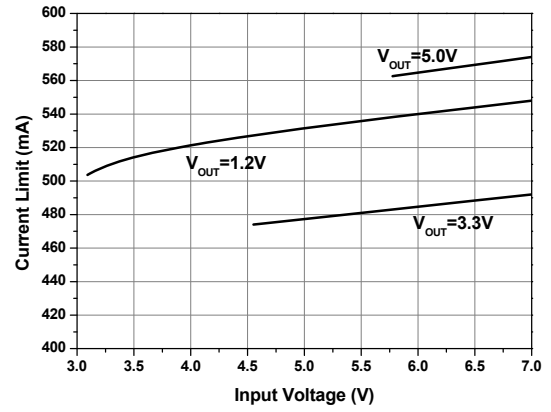

Fig.8 Current Limit vs. Input Voltage

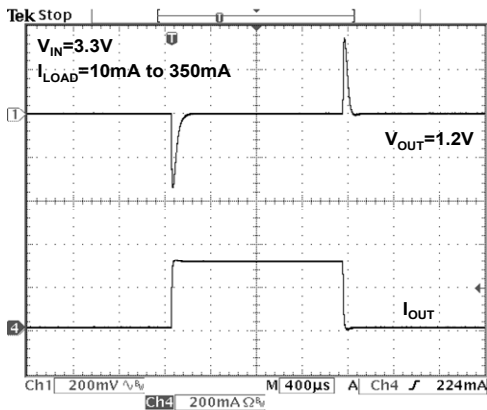

Fig.9 Load Transient Response at $V_{IN}=3.3V$, $V_{OUT}=1.2V$

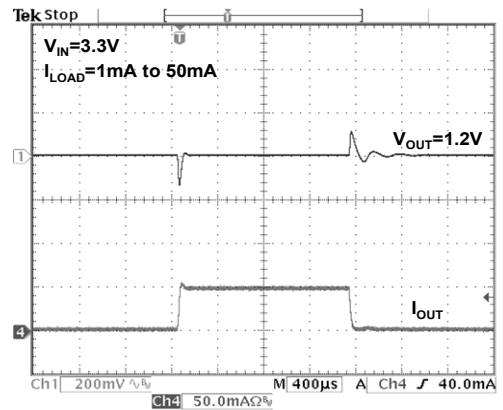

Fig.10 Load Transient Response at $V_{IN}=3.3V$, $V_{OUT}=1.2V$

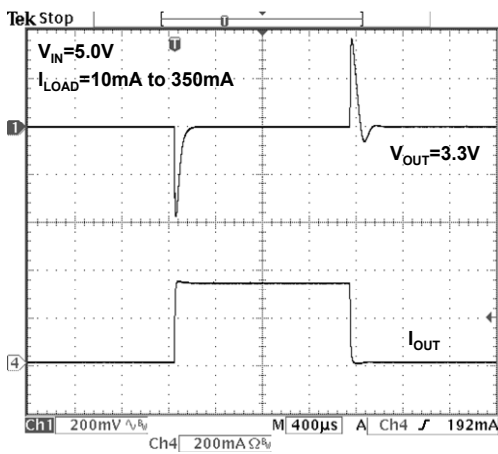

Fig.11 Load Transient Response at $V_{IN}=5.0V$, $V_{OUT}=3.3V$

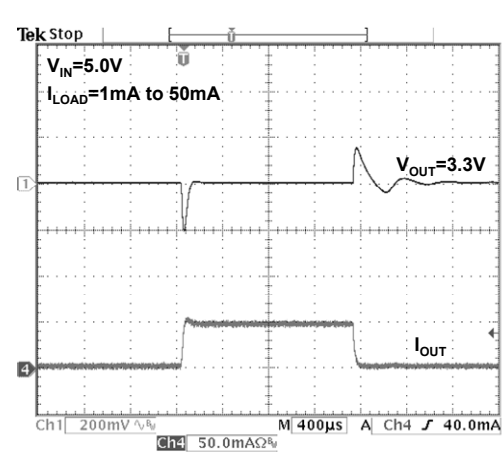

Fig.12 Load Transient Response at $V_{IN}=5.0V$, $V_{OUT}=3.3V$

■ TYPICAL PERFORMANCE CHARACTERISTICS (Continued)

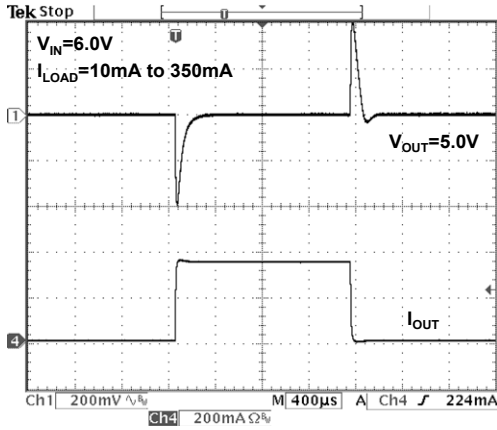

Fig.13 Load Transient Response at $V_{IN}=6.0V$, $V_{OUT}=5.0V$

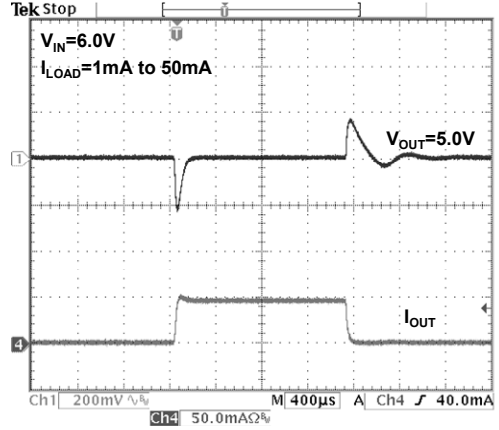

Fig.14 Load Transient Response at $V_{IN}=6.0V$, $V_{OUT}=5.0V$

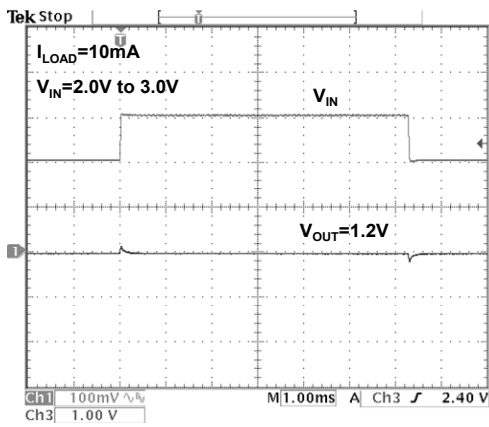

Fig.15 Line Transient Response at $V_{OUT}=1.2V$, $I_{OUT}=10mA$

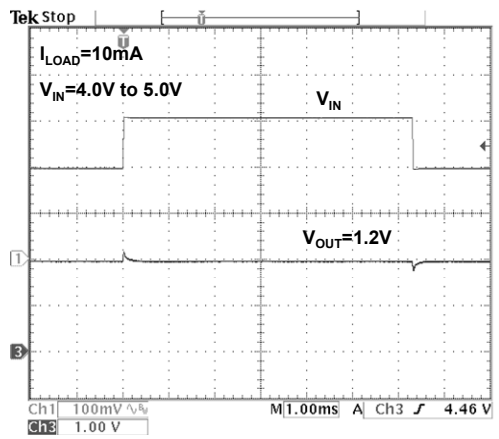

Fig.16 Line Transient Response at $V_{OUT}=1.2V$, $I_{OUT}=10mA$

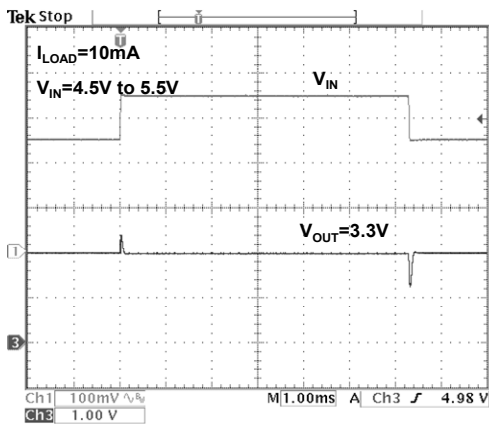

Fig.17 Line Transient Response at $V_{OUT}=3.3V$, $I_{OUT}=10mA$

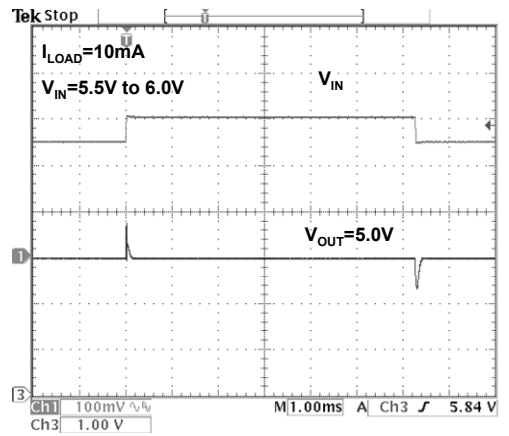

Fig.18 Line Transient Response at $V_{OUT}=5.0V$, $I_{OUT}=10mA$

■ TYPICAL PERFORMANCE CHARACTERISTICS (Continued)

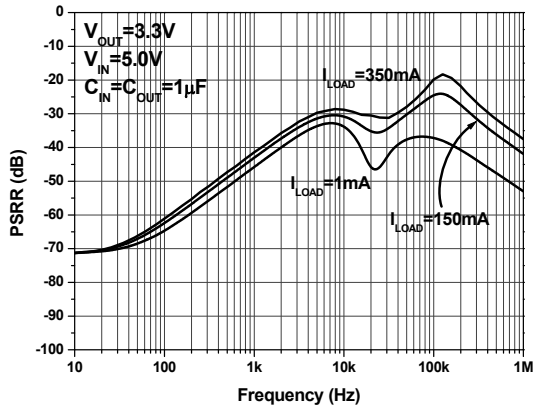

Fig 19. PSRR vs. Frequency

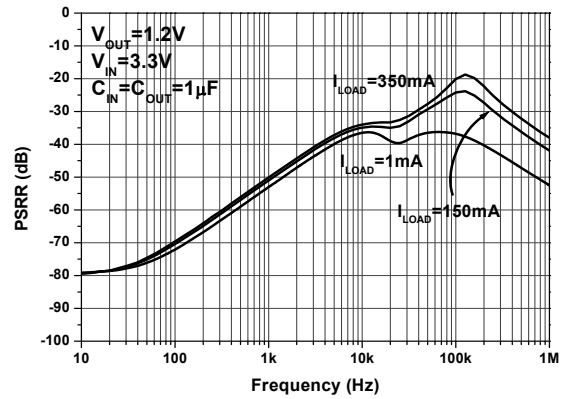

Fig 20. PSRR vs. Frequency

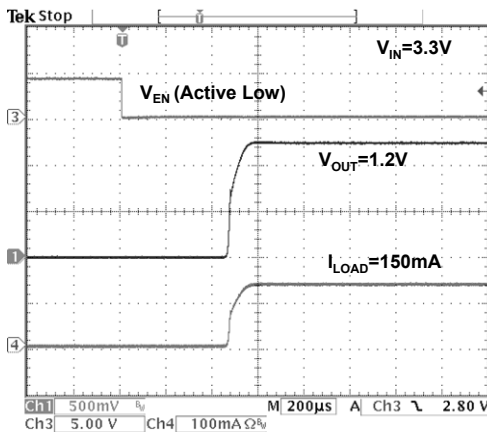

Fig.21 Start-Up Waveform at $V_{OUT}=1.2V$, $I_{OUT}=150mA$

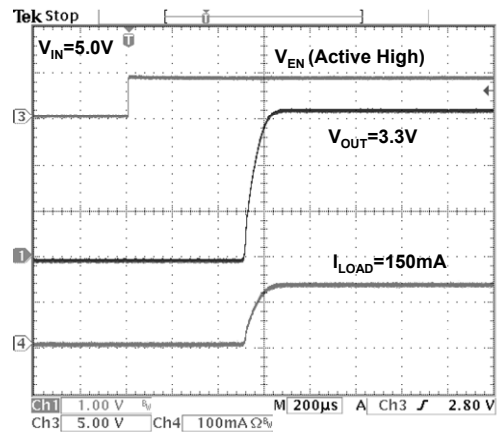

Fig.22 Start-Up Waveform at $V_{OUT}=3.3V$, $I_{OUT}=150mA$

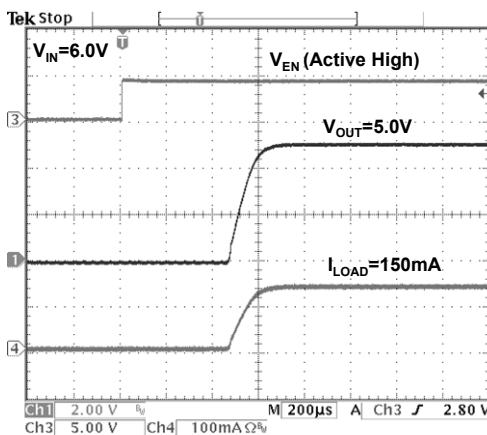

Fig.23 Start-Up Waveform at $V_{OUT}=5.0V$, $I_{OUT}=150mA$

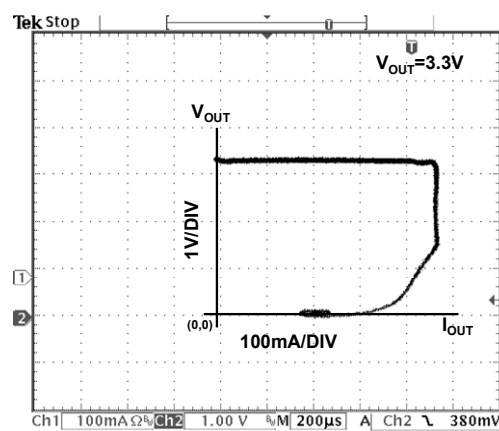
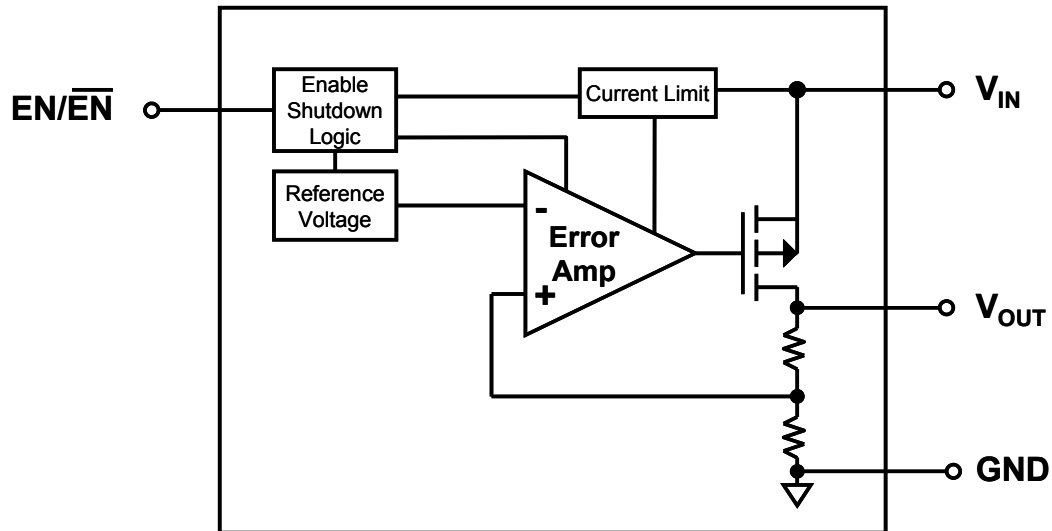

Fig.24 Current Foldback at $V_{IN}=5.0V$, $V_{OUT}=3.3V$

■ BLOCK DIAGRAM

■ PIN DESCRIPTION

V _{IN}	PIN	– Power supply input pin. Bypass with a 1μF ceramic capacitor to GND
V _{OUT}	PIN	– Regulator Output pin. Sources up to 350mA.
EN	PIN	– Chip Enable (Active High). This pin isn't allowed to float.
$\overline{\text{EN}}$	PIN	– Chip Enable (Active Low). This pin isn't allowed to float.
GND	PIN	– Ground.

APPLICATION INFORMATION

The AIC1702 is a high performance linear regulator that provides low-dropout voltage and low quiescent-current. The device is available in a fixed output voltages ranging from 0.8V to 5.0V, and the device can supply loads up to 350mA.

Capacitor Selection

Linear regulators require input and output capacitors to maintain stability. Input capacitor with a 1 μ F, output capacitor with a 1 μ F ceramic output capacitor is recommended. When choosing the input and output ceramic capacitors, X5R and X7R types are recommended because they retain their capacitance over wider ranges of voltage and temperature than other types.

Current Limit

The AIC1702 includes a current limiter, which monitors and controls the maximum output current. If the output is overloaded or shorted to ground, this can protect the device from being damaged.

Dropout Voltage

The minimum input-output voltage differential (dropout) determines the lowest usable supply voltage. The dropout voltage is a function of drain-to-source on resistance multiplied by the load current.

Thermal Protection

The AIC1702 includes a thermal-limiting circuit, which is designed to protect the device against overload

condition. When the junction temperature exceeds $T_J=135^{\circ}\text{C}$, the thermal-limiting circuit turns off the pass transistor and allows the IC to cool. For continuous load condition, maximum rating of junction temperature must not be exceeded.

Power Dissipation

The maximum power dissipation of AIC1702 depends on the thermal resistance of its case and circuit board, the temperature difference between the die junction and ambient air, and the rate of airflow. The rate of temperature rise is greatly affected by the mounting pad configuration on the PCB, the board material, and the ambient temperature. When the IC mounting with good thermal conductivity is used, the junction temperature will be low even when large power dissipation applies.

The power dissipation across the device is

$$P = I_{\text{OUT}} (V_{\text{IN}} - V_{\text{OUT}})$$

The maximum power dissipation is:

$$P_{\text{MAX}} = \frac{(T_{\text{J-max}} - T_{\text{A}})}{R\theta_{\text{JA}}}$$

Where $T_{\text{J-max}}$ is the maximum allowable junction temperature (135°C), and T_{A} is the ambient temperature suitable in application.

As a general rule, the lower temperature is, the better reliability of the device is. So the PCB mounting pad should provide maximum thermal conductivity to maintain low device temperature.

APPLICATION CIRCUIT

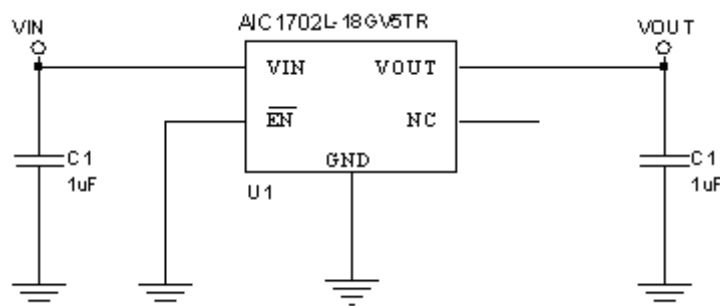

■ PHYSICAL DIMENSIONS (unit: mm)

● SOT-23 PACKAGE OUTLINE DRAWING

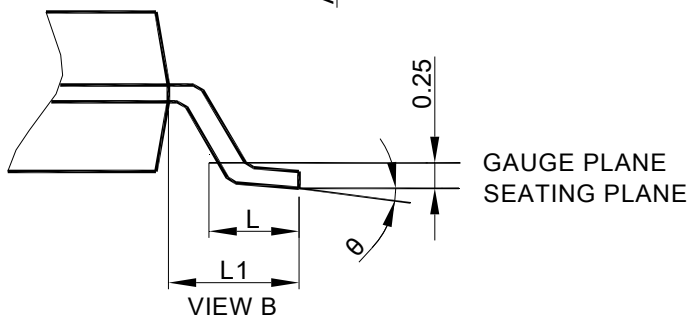
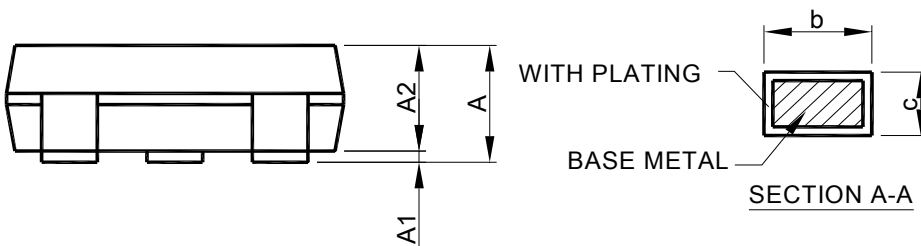
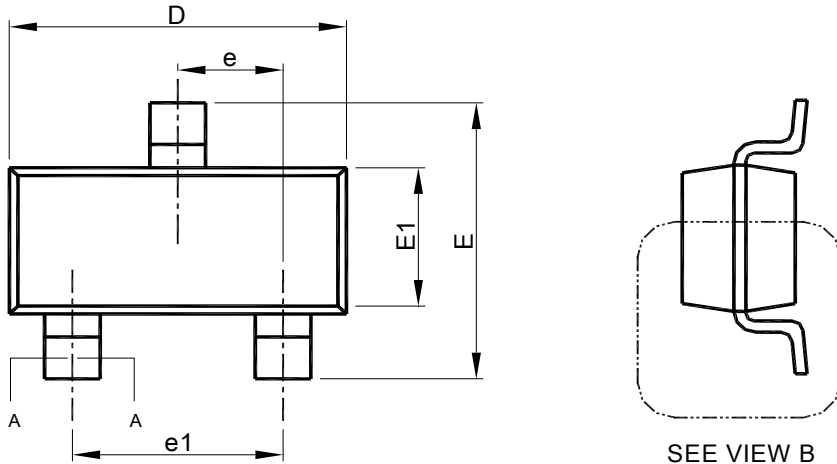

SYMBOL	SOT-23	
	MILLIMETERS	
	MIN.	MAX.
A	0.95	1.45
A1	0.00	0.15
A2	0.90	1.30
b	0.30	0.50
c	0.08	0.22
D	2.80	3.00
E	2.60	3.00
E1	1.50	1.70
e	0.95 BSC	
e1	1.90 BSC	
L	0.30	0.60
L1	0.60 REF	
θ	0°	8°

- Note: 1. Refer to JEDEC MO-178.
 2. Dimension "D" does not include mold flash, protrusions or gate burrs. Mold flash, protrusion or gate burrs shall not exceed 10 mil per side.
 3. Dimension "E1" does not include inter-lead flash or protrusions.
 4. Controlling dimension is millimeter, converted inch dimensions are not necessarily exact.

● SOT-23-5 PACKAGE OUTLINE DRAWING

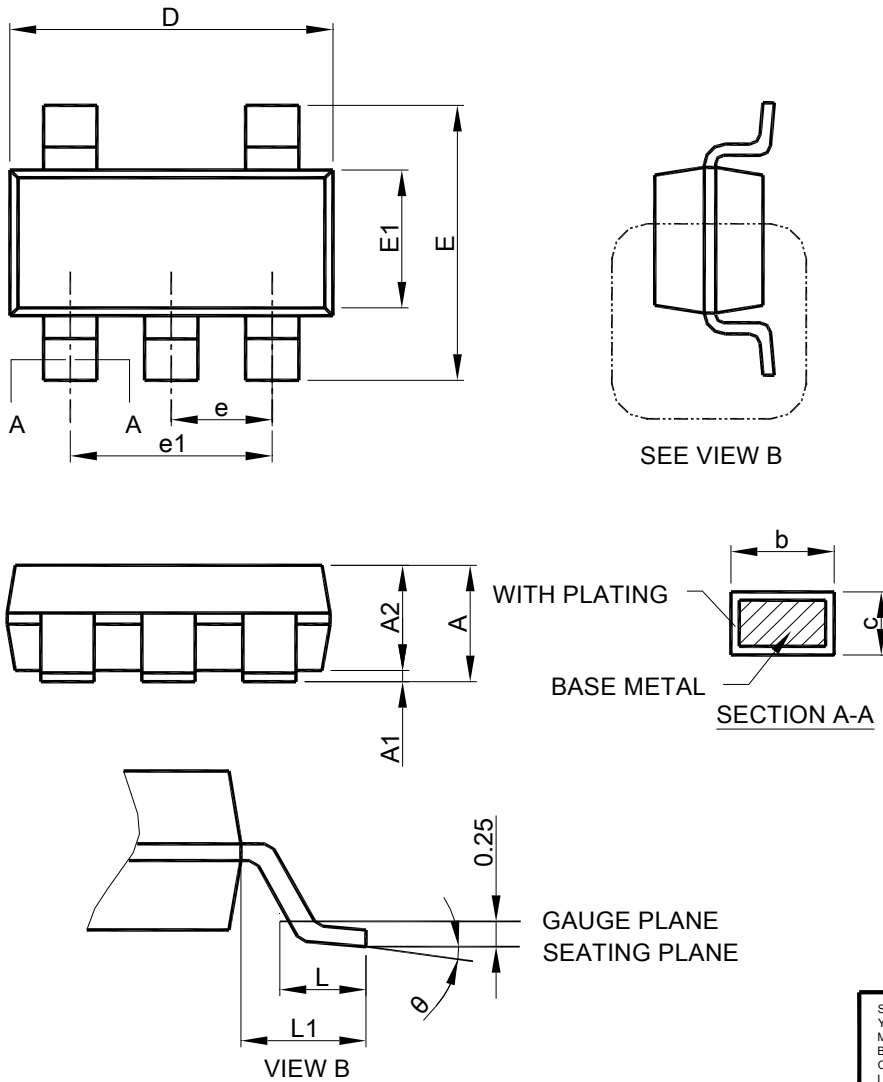

- Note : 1. Refer to JEDEC MO-178AA.
 2. Dimension "D" does not include mold flash, protrusions or gate burrs. Mold flash, protrusion or gate burrs shall not exceed 10 mil per side.
 3. Dimension "E1" does not include inter-lead flash or protrusions.
 4. Controlling dimension is millimeter, converted inch dimensions are not necessarily exact.

SYMBOL	SOT-23-5	
	MILLIMETERS	
	MIN.	MAX.
A	0.95	1.45
A1	0.00	0.15
A2	0.90	1.30
b	0.30	0.50
c	0.08	0.22
D	2.80	3.00
E	2.60	3.00
E1	1.50	1.70
e	0.95 BSC	
e1	1.90 BSC	
L	0.30	0.60
L1	0.60 REF	
θ	0°	8°

● SOT-89 PACKAGE OUTLINE DRAWING

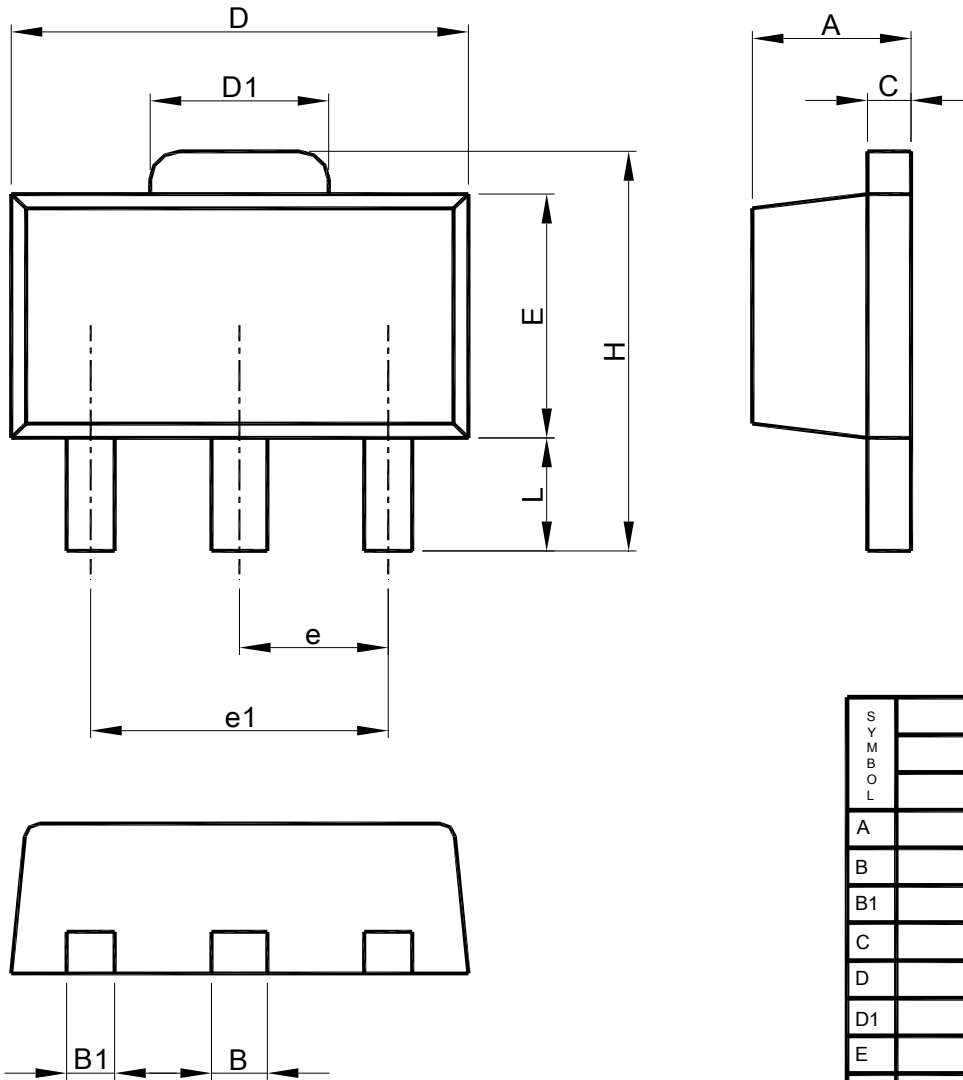

SYMBOL	SOT-89	
	MILLIMETERS	
	MIN.	MAX.
A	1.40	1.60
B	0.44	0.56
B1	0.36	0.48
C	0.35	0.44
D	4.40	4.60
D1	1.50	1.83
E	2.29	2.60
e	1.50 BSC	
e1	3.00 BSC	
H	3.94	4.25
L	0.89	1.20

- Note: 1. Refer to JEDEC TO-243AA.
 2. Dimension "D" does not include mold flash, protrusions or gate burrs. Mold flash, protrusion or gate burrs shall not exceed 6 mil per side.
 3. Dimension "E" does not include inter-lead flash or protrusions.
 4. Controlling dimension is millimeter, converted inch dimensions are not necessarily exact.

● DFN 6L-2x2x0.75-0.65mm PACKAGE OUTLINE DRAWING

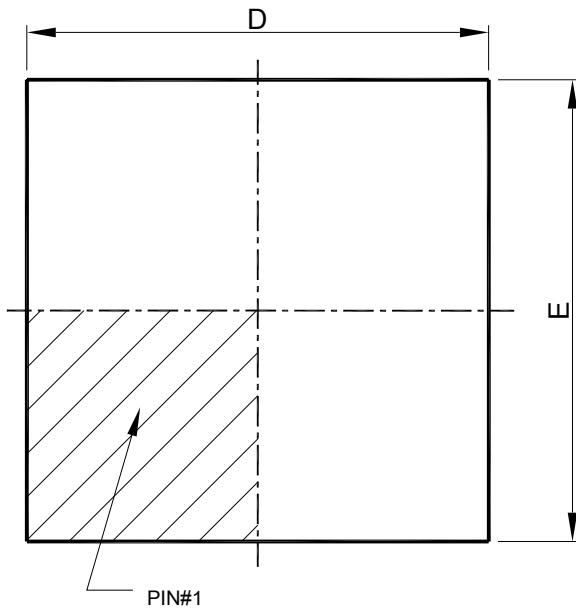

TOP VIEW

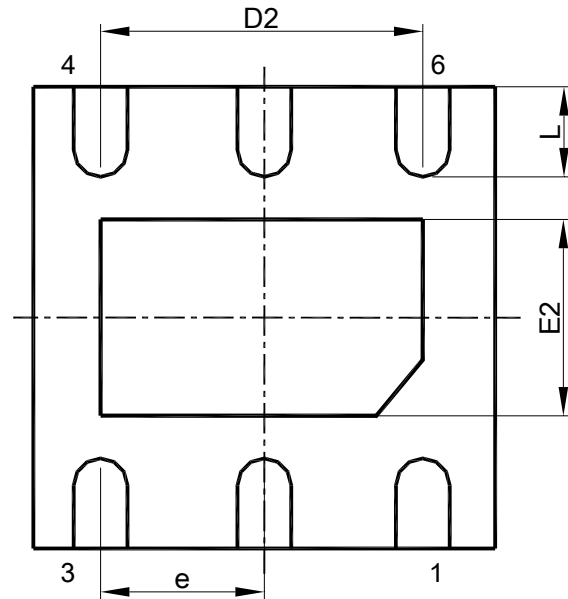

BOTTOM VIEW

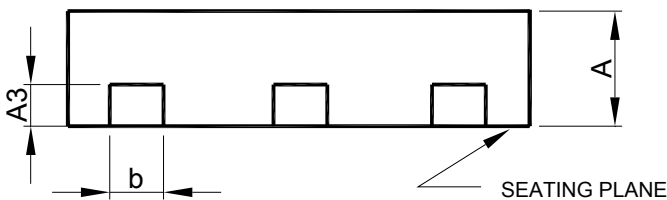

SIDE VIEW

SYMBOL	DFN 6L-2x2x0.75-0.65mm	
	MILLIMETERS	
	MIN.	MAX.
A	0.70	0.80
A3	0.20 BSC	
b	0.25	0.35
D	2.00 BSC	
D2	1.20	1.60
E	2.00 BSC	
E2	0.55	0.85
e	0.65 BSC	
L	0.25	0.45

- Note : 1. DIMENSION AND TOLERANCING CONFORM TO ASME Y14.5M-1994.
 2. CONTROLLING DIMENSIONS : MILLIMETER , CONVERTED INCH DIMENSION ARE NOT NECESSARILY EXACT.
 3. DIMENSION b APPLIES TO METALLIZED TERMINAL AND IS MEASURED BETWEEN 0.10 AND 0.25 mm FROM TERMINAL TIP.

Note:

Information provided by AIC is believed to be accurate and reliable. However, we cannot assume responsibility for use of any circuitry other than circuitry entirely embodied in an AIC product; nor for any infringement of patents or other rights of third parties that may result from its use. We reserve the right to change the circuitry and specifications without notice.

Life Support Policy: AIC does not authorize any AIC product for use in life support devices and/or systems. Life support devices or systems are devices or systems which, (i) are intended for surgical implant into the body or (ii) support or sustain life, and whose failure to perform, when properly used in accordance with instructions for use provided in the labeling, can be reasonably expected to result in a significant injury to the user.