

High PSRR, 600mA Linear Regulator With Bypass Pin

FEATURES

- Guarantee 600mA Output Current.
- Fast Response in Line/Load Transient.
- Wide Operating Voltage Ranges: 2.3V to 6.0V.
- $<0.01 \mu A$ Shutdown Standby Current.
- Low Quiescent Current : $<100\mu A$.
- Fixed: 0.8V, 1.2V, 1.8V, 2.5V, 2.85V, 3.3V Output Voltage.
- Adjustable Output Voltage are available from 0.8~4.5V.
- Low Dropout : 350mV at 600mA load current and 3.3V output voltage.
- High PSRR : 65dB at 1kHz.
- Active Low or High Shutdown Control.
- Current Limit, Current Foldback and Thermal Protection.
- Available in $\pm 2\%$ Output Tolerance.
- Available in 3 & 5 lead of SOT23, SOT89, TO252 & 3 lead of SOT223 Package.

APPLICATIONS

- Cellular Phones
- PCMCIA Cards
- Laptop, Palmtops, Notebook Computers
- Personal Communication Equipment
- PDAs
- Digital Still Cameras
- Portable Consumer Equipments

DESCRIPTION

A low noise, high PSRR and ultra low dropout linear regulator AIC1748 is optimized for low ESR ceramic capacitors operation with 600mA continuous current. The AIC1748 is designed for portable and wireless devices with demanding performance and space requirements.

The AIC1748 offers high precision output voltage of $\pm 2\%$ tolerance. Output voltage can also be available on demand for those other than the preset values.

A noise bypass pin is available for further reduction of output noise. At 600mA load current and 3.3V output voltage, a 350mV dropout is performed. The quality of low quiescent current and low dropout voltage makes this device ideal for battery power applications. The high ripple rejection and low noise of the AIC1748 provide enhanced performances for critical applications such as cellular phones, and PDAs.

In addition, a logic-level shutdown input is included, which reduce supply current to less than $0.01 \mu A$ (typ.) in shutdown mode with fast turn-on & off time less than $50 \mu s$ & $30 \mu s$. The AIC1748's current limit and thermal protection provide protection against any overload condition that would create excessive junction temperatures.

TYPICAL APPLICATION CIRCUIT

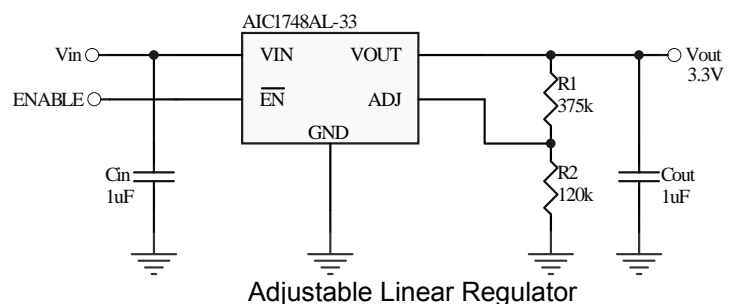
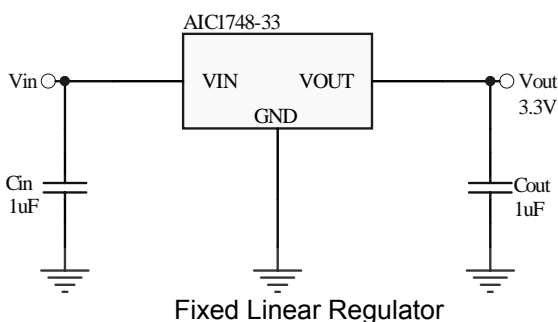

ORDERING INFORMATION

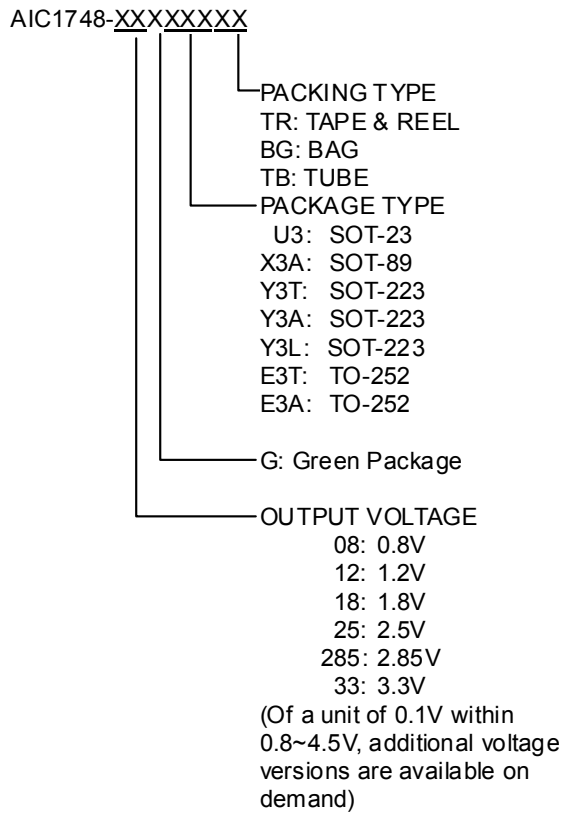

Example: AIC1748-18GX3ATR
 → 1.8V Version, in SOT-89 Green Package and Tape & Reel Packing Type

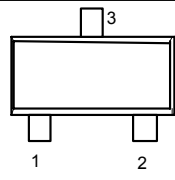
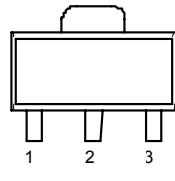
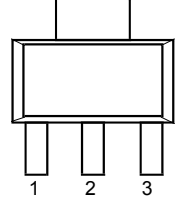
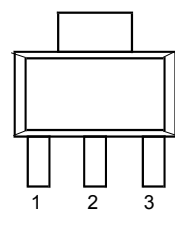
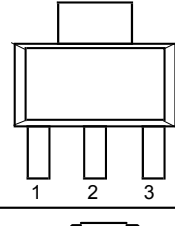
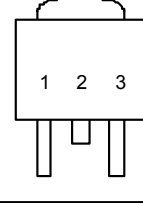
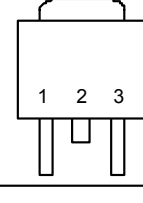
3 PIN CONFIGURATION	
SOT-23 (U3) TOP VIEW 1: GND 2: VOUT 3: VIN	
SOT-89 (X3A) TOP VIEW 1: GND 2: VIN (TAB) 3: VOUT	
SOT-223 (Y3T) TOP VIEW 1: VOUT 2: GND (TAB) 3: VIN	
SOT-223 (Y3A) TOP VIEW 1: GND 2: VOUT (TAB) 3: VIN	
SOT-223 (Y3L) TOP VIEW 1: GND 2: VIN (TAB) 3: VOUT	
TO-252 (E3T) TOP VIEW 1: VOUT 2: GND (TAB) 3: VIN	
TO-252 (E3A) TOP VIEW 1: GND 2: VOUT (TAB) 3: VIN	

■ ORDERING INFORMATION (Continued)

AIC1748XX-XXX XX XX

PACKING TYPE
 TR: TAPE & REEL
 BG: BAG
 TB: TUBE
 PACKAGE TYPE
 V5: SOT-23-5
 X5: SOT-89-5
 E5: TO-252-5

G: Green Package

OUTPUT VOLTAGE
 08: 0.8V
 12: 1.2V
 18: 1.8V
 25: 2.5V
 285: 2.85V
 33: 3.3V
 (Of a unit of 0.1V within
 0.8~4.5V, additional voltage
 versions are available on
 demand)

ENABLE TYPE
 L: Chip Enable Low
 H: Chip Enable High
 B: Bypass
 A: ADJ

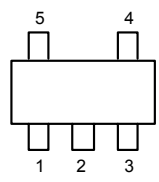
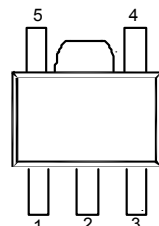
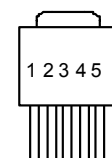
5 PIN CONFIGURATION	
SOT-23-5 (V5) TOP VIEW 1: VIN 2: GND 3: $\overline{\text{EN}}/\text{EN}$ 4: BP/ADJ 5: VOUT	
SOT89-5 (X5) TOP VIEW 1: VIN 2: GND 3: $\overline{\text{EN}}/\text{EN}$ 4: BP/ADJ 5: VOUT	
TO-252-5 (E5) TOP VIEW 1: $\overline{\text{EN}}/\text{EN}$ 2: VIN 3: GND (TAB) 4: VOUT 5: BP/ADJ	

Example: AIC1748BH-18GV5TR

→ With Bypass Pin, Chip Enable high,
 1.8V Version, in SOT-23-5 Green
 Package and Tape & Reel Packing Type

• Marking

Part No.	Package Type	Marking
AIC1748-xxGX3A	SOT-89	GAxxG
AIC1748BH-xxGX5	SOT-89-5	GBxxG
AIC1748BL-xxGX5	SOT-89-5	GCxxG
AIC1748AH-xxGX5	SOT-89-5	GIxxG
AIC1748AL-xxGX5	SOT-89-5	GJxxG
AIC1748-xxGU3	SOT-23	GDxxG
AIC1748BH-xxGV5	SOT-23-5	GExxG
AIC1748BL-xxGV5	SOT-23-5	GFxxG
AIC1748AH-xxGV5	SOT-23-5	GGxxG
AIC1748AL-xxGV5	SOT-23-5	GHxxG
AIC1748-xxGY3A	SOT-223	GKxxG
AIC1748-xxGY3T	SOT-223	GLxxG
AIC1748-xxGY3L	SOT-223	GXxxG

xx represents voltage version. (08=0.8V, 09=0.9V, 10=1.0V,....., 45=4.5V)

Part No.	Package Type	Marking
AIC1748-285GX3A	SOT-89	GA2JG
AIC1748BH-285GX5	SOT-89-5	GB2JG
AIC1748BL-285GX5	SOT-89-5	GC2JG
AIC1748AH-285GX5	SOT-89-5	GI2JG
AIC1748AL-285GX5	SOT-89-5	GJ2JG
AIC1748-285GU3	SOT-23	GD2JG
AIC1748BH-285GV5	SOT-23-5	GE2JG
AIC1748BL-285GV5	SOT-23-5	GF2JG
AIC1748AH-285GV5	SOT-23-5	GG2JG
AIC1748AL-285GV5	SOT-23-5	GH2JG
AIC1748-285GY3A	SOT-223	GK2JG
AIC1748-285GY3T	SOT-223	GL2JG
AIC1748-285GY3L	SOT-223	GX2JG

■ ABSOLUTE MAXIMUM RATINGS

Input Voltage	7V
EN Pin Voltage	7V
Noise Bypass Terminal Voltage	7V
Operating Temperature Range	-40°C~85°C
Maximum Junction Temperature.....	150°C
Storage Temperature Range	-65°C~150°C
Lead Temperature (Soldering, 10 sec)	260°C
Thermal Resistance Junction to Case	
SOT-23	115°C /W
SOT-223	15°C /W
TO-252.....	8°C /W
SOT-89	45°C /W
Thermal Resistance Junction to Ambient	
SOT-23	250°C /W
(Assume no ambient airflow, no heatsink) SOT-223.....	130°C /W
TO-252.....	100°C /W
SOT-89	160°C /W

Absolute Maximum Ratings are those values beyond which the life of a device may be impaired.

■ ELECTRICAL CHARACTERISTICS
($C_{IN} = C_{OUT} = 1\mu F$, $C_{BP} = 0.1nF$, $V_{IN} = V_{OUT} + 1V$, $T_J = 25^\circ C$, unless otherwise specified) (Note 1)

PARAMETER	TEST CONDITIONS	SYMBOL	MIN.	TYP.	MAX.	UNIT
Input Voltage (Note 2)		V_{IN}	2.3		6.0	V
Output Voltage Tolerance	$V_{IN} = 6.0V$, $I_{OUT} = 1mA$	V_{OUT}	-2		2	%
Continuous Output Current		I_{OUT}	600			mA
Quiescent Current	Chip Enable Low, $V_{EN} \leq 0.4V$, $I_{OUT} = 0 mA$ Chip Enable High, $V_{EN} \geq 1.2V$, $I_{OUT} = 0 mA$	I_Q		75	110	μA
GND Pin Current	Chip Enable Low, $V_{EN} \leq 0.4V$, $I_{OUT} = 600mA$ Chip Enable High, $V_{EN} \geq 1.2V$, $I_{OUT} = 600mA$	I_{GND}		75	110	μA
Standby Current	Chip Enable Low, $V_{EN} = V_{IN}$ Chip Enable High, $V_{EN} = 0$	I_{STBY}		0.01	0.1	μA
Output Current Limit		I_{IL}	660	950	1300	mA
Dropout Voltage	$I_{OUT} = 600 mA$, $V_{OUT} = 1.2V$	V_{DROP}		1000	1200	mV
	$I_{OUT} = 600 mA$, $V_{OUT} = 1.8V$			500	650	
	$I_{OUT} = 600 mA$, $V_{OUT} = 3.3V$			350	450	
	$I_{OUT} = 600 mA$, $V_{OUT} = 4.5V$			340	440	
Line Regulation	$V_{IN} = V_{OUT} + 1V$ to 5.5V	ΔV_{LIR}		3	15	mV
Load Regulation	$I_{OUT} = 1mA$ to 600mA	ΔV_{LOR}		3	20	mV
Ripple Rejection	f=1KHz, Ripple=0.5Vp-p,	PSRR		65		dB
Output Noise Voltage	$C_{BP} = 0.1nF$, f= 10~100KHz			24		μV_{rms}
Noise Bypass Terminal Voltage		V_{REF}		0.8		V
Short Current	$V_{IN} = V_{OUT} + 1V$ & $V_{OUT} = 0V$	I_{SHORT}		250		mA
Temperature Coefficient		TC		50		ppm/ $^\circ C$
Thermal Shutdown Temperature	$V_{IN} = V_{OUT} + 1V$	T_{SD}		150		$^\circ C$
Thermal Shutdown Hysteresis		ΔT_{SD}		40		$^\circ C$
ADJ Pin Specifications						
ADJ Pin Current	$V_{ADJ} = V_{REF}$	I_{ADJ}		10	100	nA
ADJ Pin Threshold		$V_{TH(ADJ)}$	0.05	0.1	0.2	V
ADJ Pin Voltage Tolerance		V_{ADJ}	0.784	0.8	0.816	V

ELECTRICAL CHARACTERISTICS (Continued)

PARAMETER	TEST CONDITIONS	SYMBOL	MIN.	TYP.	MAX.	UNIT
Shutdown Pin SPECIFICATIONS						
Shutdown Pin Current	$V_{EN} = V_{IN}$ or GND	I_{EN}		0	100	nA
Shutdown Exit Delay Time	$I_{OUT} = 30\text{mA}$	Δt		50		μS
Max Output Discharge Resistance to GND during Shutdown		R_{DSON_CLMP}		30		Ω
Shutdown Time				30		μS
Shutdown Input Threshold	Chip Enable Low, Output OFF, $V_{IN} = 2.3\text{V}$ to 6.0V	V_{ENH}	1.2			V
	Chip Enable High, Output ON, $V_{IN} = 2.3\text{V}$ to 6.0V					
	Chip Enable Low, Output ON, $V_{IN} = 2.3\text{V}$ to 6.0V	V_{ENL}			0.4	
	Chip Enable High, Output OFF, $V_{IN} = 2.3\text{V}$ to 6.0V					

Note 1: Specifications are production tested at $T_A = 25^\circ\text{C}$. Specifications over the -40°C to 85°C operating temperature range are assured by design^A, characterization and correlation with Statistical Quality Controls (SQC).

Note 2: $V_{IN}(\text{min})$ is the higher value of $V_{out} + \text{Dropout Voltage}$ or 2.3V .

TYPICAL PERFORMANCE CHARACTERISTICS

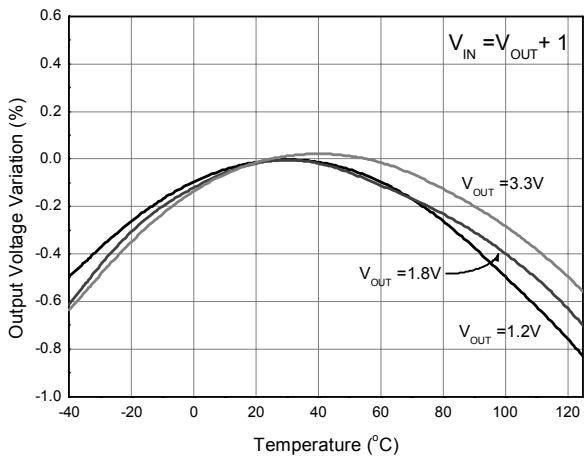

Fig.1 Output Voltage Variation vs. Temperature

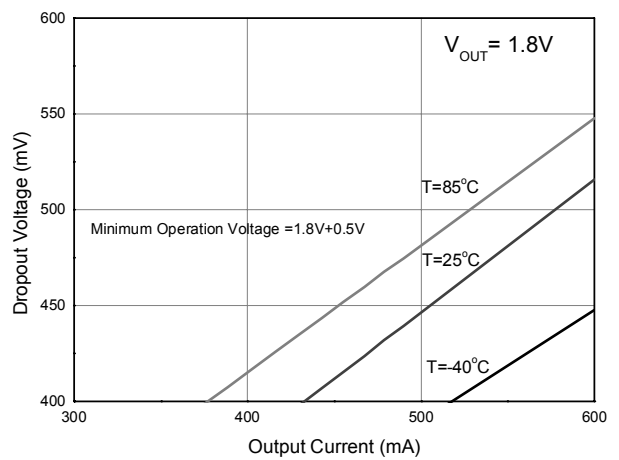

Fig.2 Dropout Voltage vs. Output Current (Vout=1.8V)

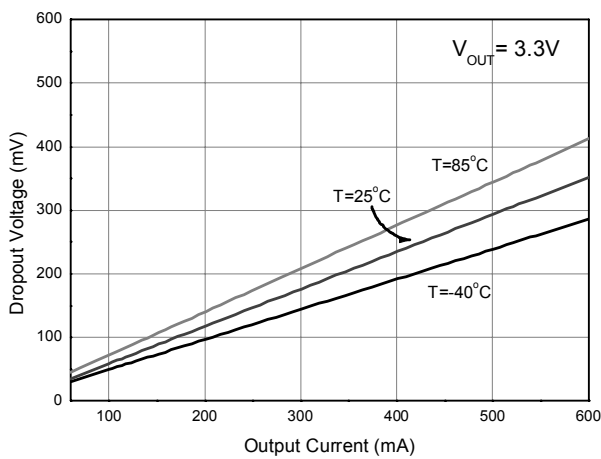

Fig.3 Dropout Voltage vs. Output Current (Vout=3.3V)

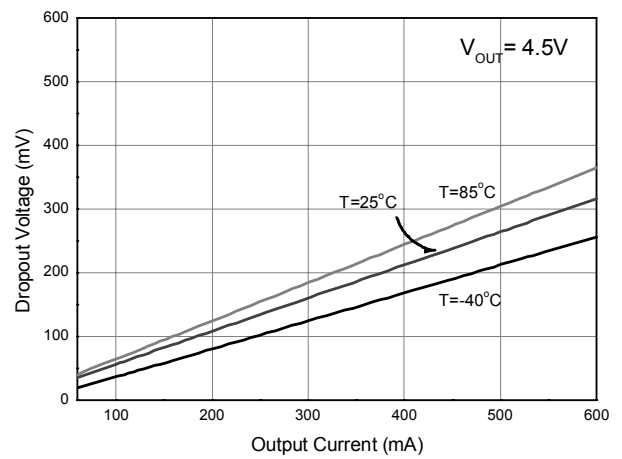

Fig.4 Dropout Voltage vs. Output Current (Vout=4.5V)

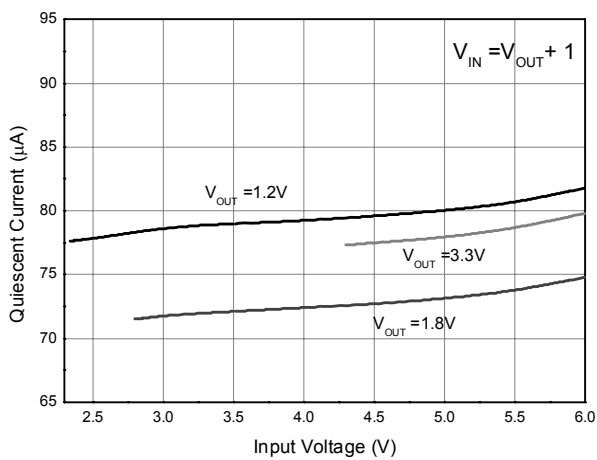

Fig.5 Quiescent Current vs. Input Voltage

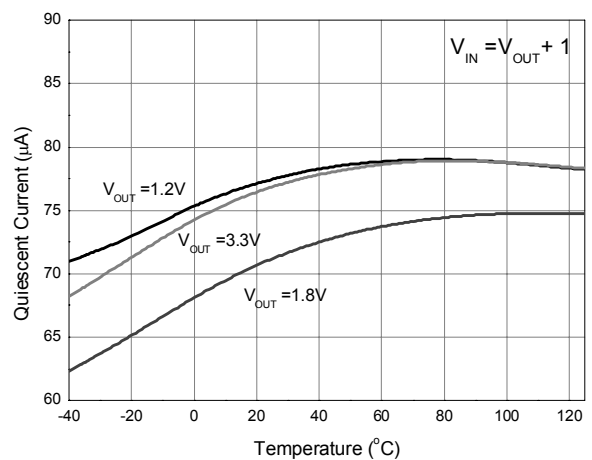

Fig.6 Quiescent Current vs. Temperature

■ TYPICAL PERFORMANCE CHARACTERISTICS (Continued)

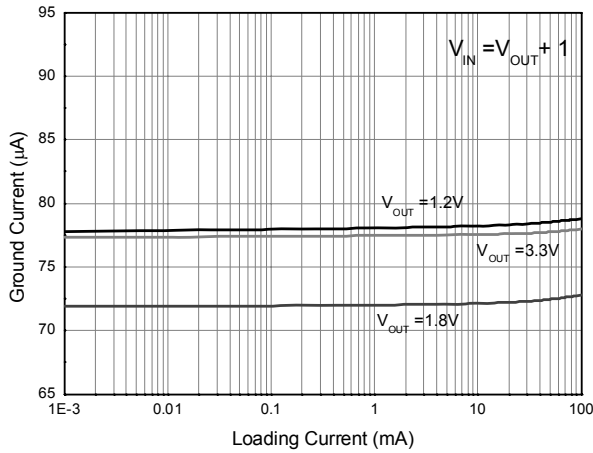

Fig.7 Ground Current vs. Loading Current

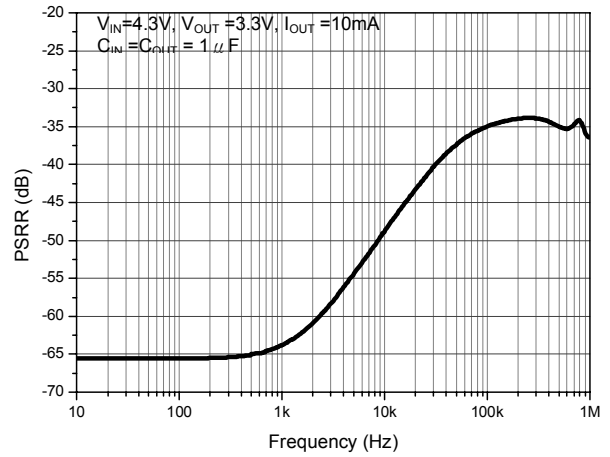

Fig.8 PSRR vs. Frequency

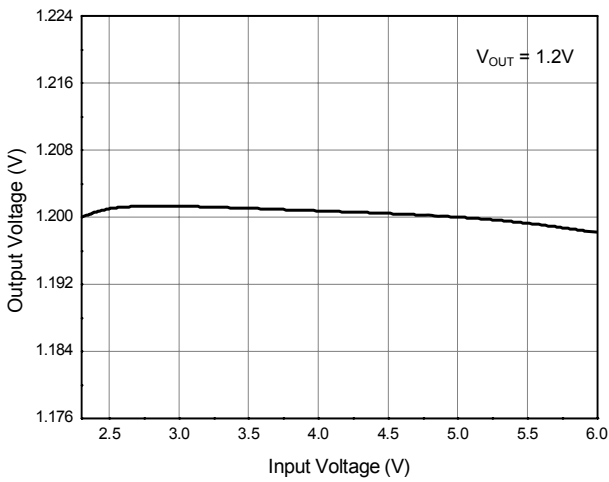

Fig.9 Output Voltage vs. Input Voltage (Vout=1.2V)

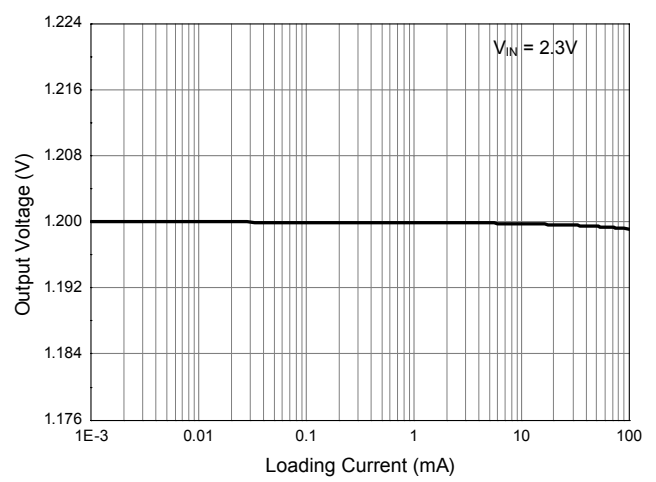

Fig.10 Output Voltage vs. Loading Current (Vout=1.2V)

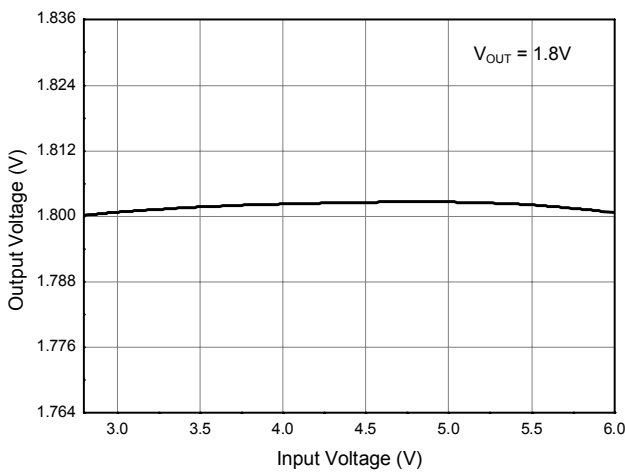

Fig.11 Output Voltage vs. Input Voltage (Vout=1.8V)

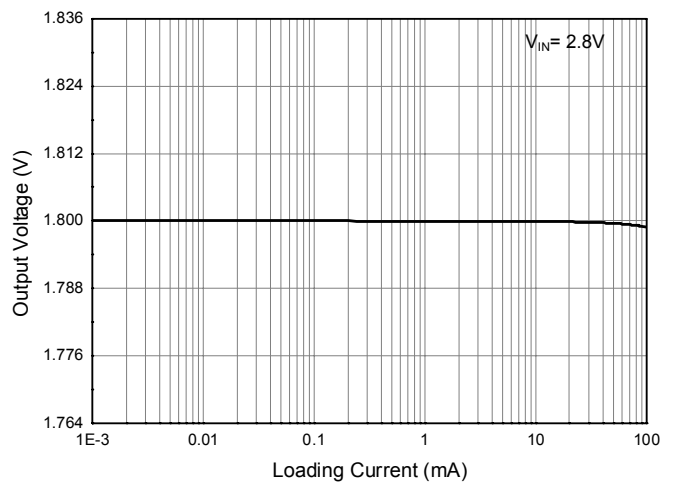

Fig.12 Output Voltage vs. Loading Current (Vout=1.8V)

■ TYPICAL PERFORMANCE CHARACTERISTICS (Continued)

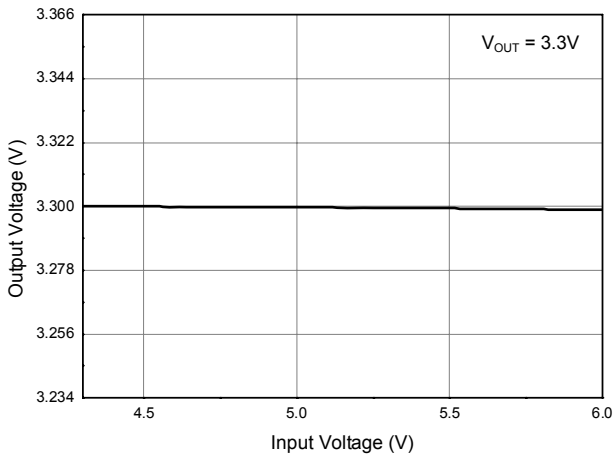

Fig.13 Output Voltage vs. Input Voltage (Vout=3.3V)

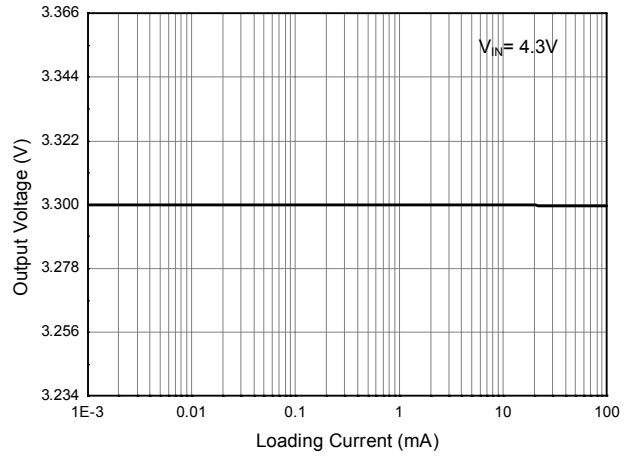

Fig.14 Output Voltage vs. Loading Current (Vout=3.3V)

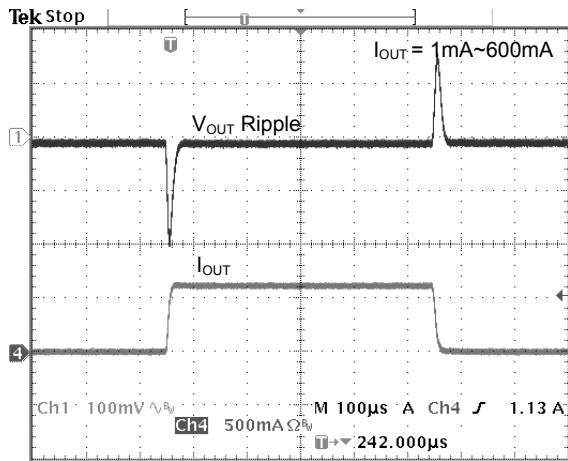

Fig.15 Load Transient Response at $V_{IN}=2.3V$, $V_{OUT}=1.2V$

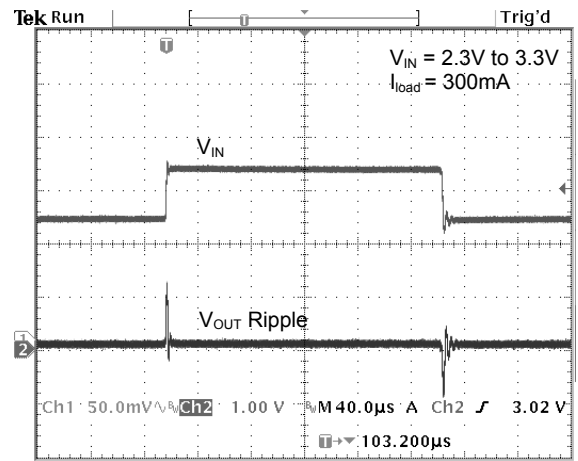

Fig.16 Line Transient Response at $V_{OUT}=1.2V$, $I_{OUT}=300mA$

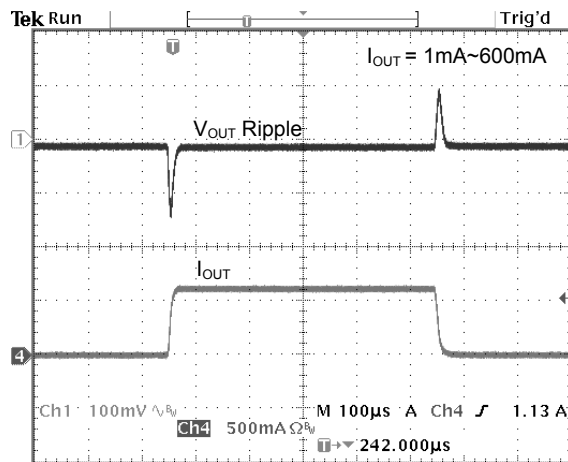

Fig.17 Load Transient Response at $V_{IN}=2.8V$, $V_{OUT}=1.8V$

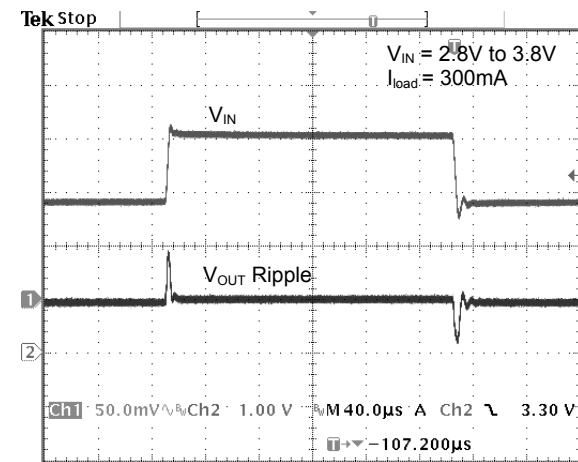

Fig.18 Line Transient Response at $V_{OUT}=1.8V$, $I_{OUT}=300mA$

■ TYPICAL PERFORMANCE CHARACTERISTICS (Continued)

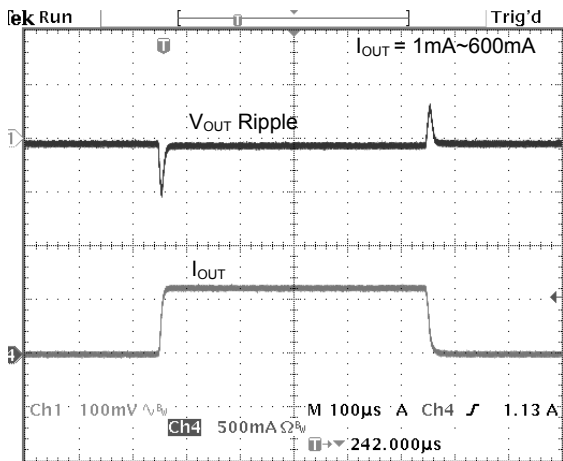

Fig.19 Load Transient Response at $V_{IN}=4.3V$, $V_{OUT}=3.3V$

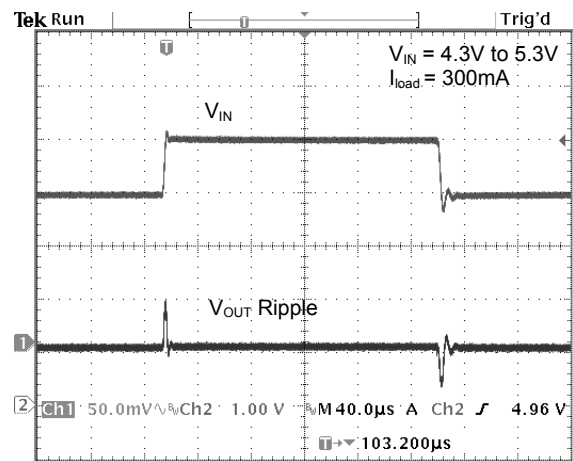

Fig.20 Line Transient Response at $V_{OUT}=3.3V$, $I_{OUT}=300mA$

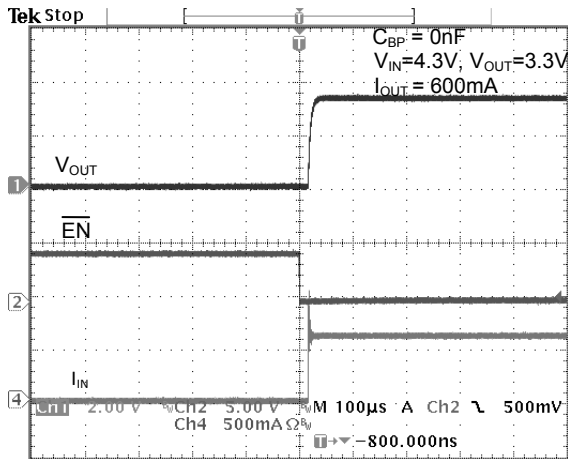

Fig.21 Start-up waveform without bypass capacitor

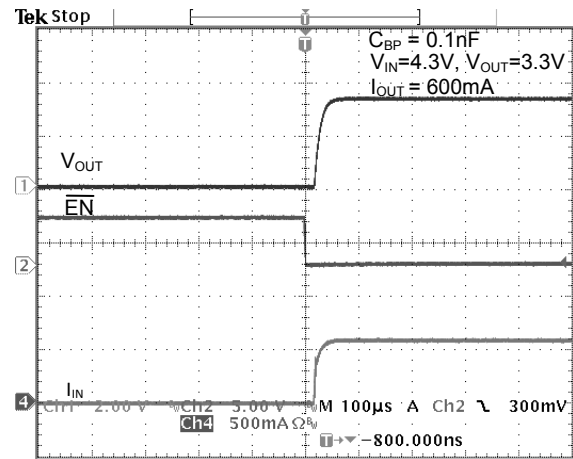

Fig.22 Start-up waveform with 0.1nF bypass capacitor

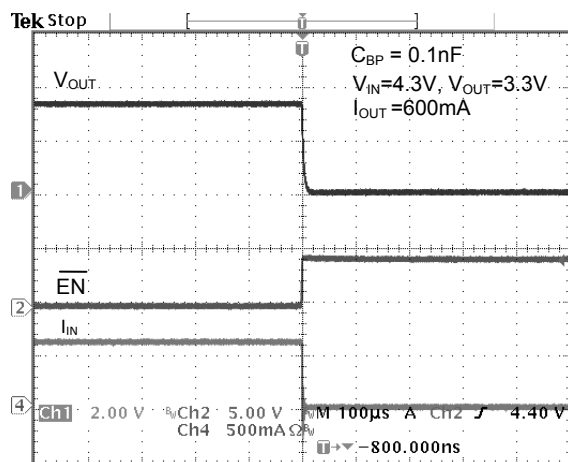

Fig.23 Shutdown transient with 0.1nF bypass capacitor

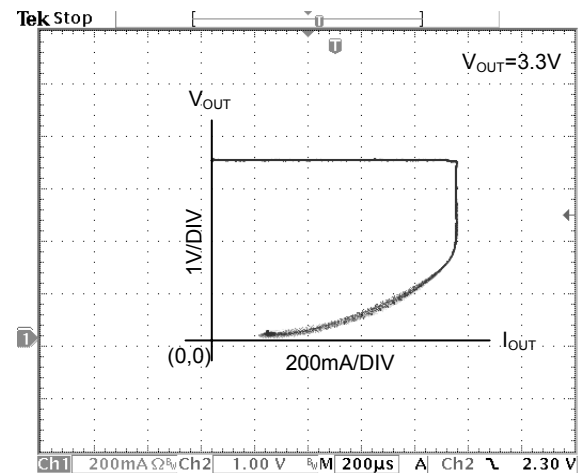
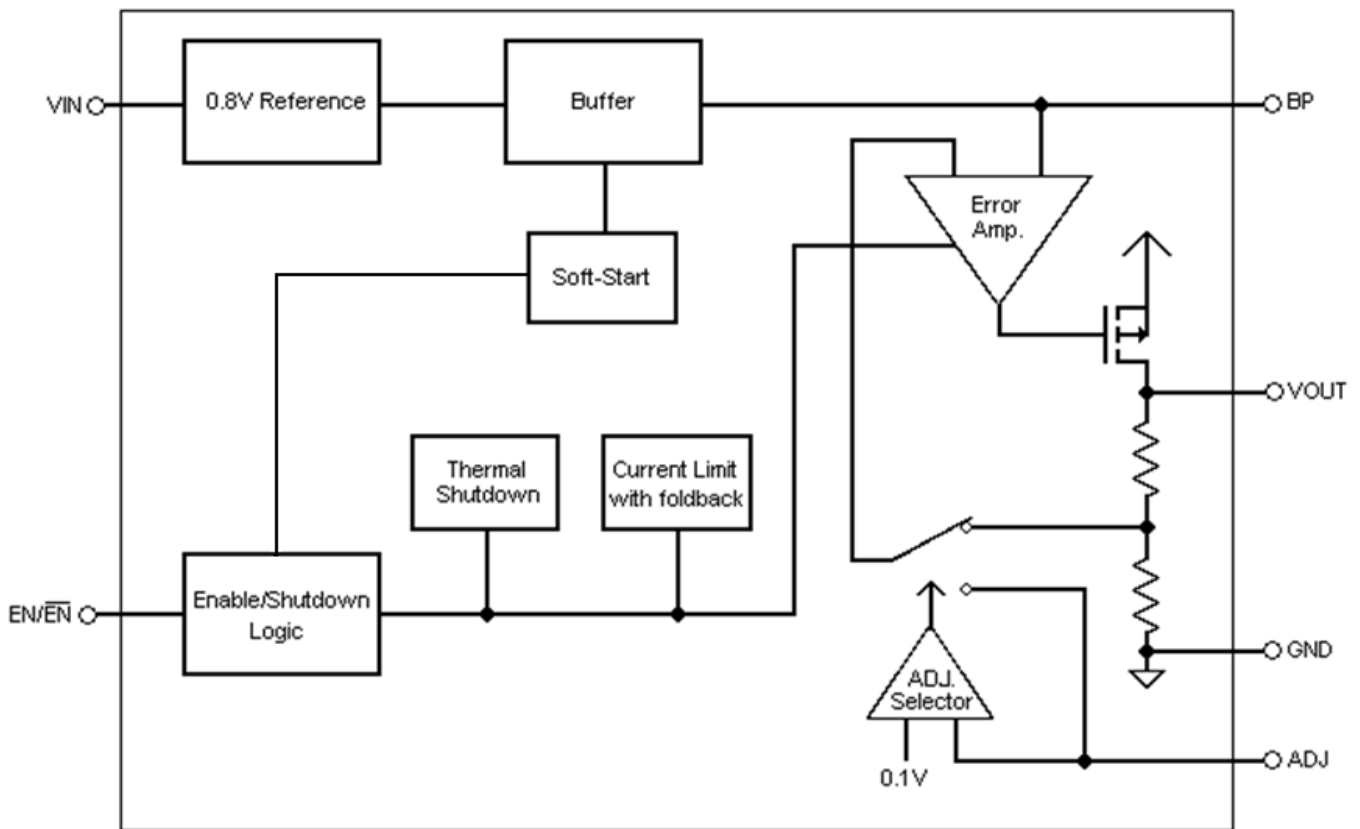

Fig.24 Current Fold Back at $V_{OUT}=3.3V$

■ BLOCK DIAGRAM

■ PIN DESCRIPTION

- VIN – Power supply input pin. Bypass with a 1 μ F capacitor to GND
- GND – Ground.
- VOUT – Regulator Output pin. Sources up to 600mA.
- $\overline{\text{EN}}$ (5 Pin) – Chip Enable (Active Low). This pin isn't allowed to float.
- EN (5 Pin) – Chip Enable (Active High). This pin isn't allowed to float.
- BP (5 Pin) – Bypass pin. It should be connected to external 0.1nF capacitor to GND to reduce output noise. The bypass pin could be floating if it's unnecessary.
- ADJ (5 Pin) – The output voltage can either be set by the internal feedback resistors when this pin is grounded, or be set by the external feedback resistors when using a resistive divider.

■ APPLICATION INFORMATION

The AIC1748 is a high performance linear regulator that provides low-dropout voltage and low quiescent-current. The device is available in an adjustable version and fixed output voltages ranging from 0.8V to 4.5V, and the device can supply loads up to 600mA.

SHUTDOWN

By connecting $\overline{\text{EN}}$ (EN) pin to V_{IN} (ground), the AIC1748 can be shut down to reduce the supply current to 0.01 μ A(typ.). At this operation mode, the output voltage of AIC1748 is equal to 0V.

CURRENT LIMIT

The AIC1748 includes a current limiter, which monitors and controls the maximum output current. If the output is overloaded or shorted to ground, this can protect the device from being damaged.

THERMAL PROTECTION

The AIC1748 includes a thermal-limiting circuit, which is designed to protect the device against overload condition. When the junction temperature exceeds $T_J=150^\circ\text{C}$, the thermal-limiting circuit turns off the pass transistor and allows the IC to cool. For continuous load condition, maximum rating of junction temperature must not be exceeded.

INPUT-OUTPUT CAPACITORS

Linear regulators require input and output capacitors to maintain stability. Input capacitor at 1 μ F with a 1 μ F ceramic output capacitor is recommended.

When choosing the input and output ceramic capacitors, X5R and X7R types are recommended because they retain their capacitance over wider ranges of voltage and temperature than other types.

NOISE BYPASS CAPACITOR

A 0.1nF bypass capacitor at BP pin can reduce output voltage noise. The bypass pin can be floating if it's unnecessary.

OUTPUT VOLTAGE PROGRAMMING

The output voltage of AIC1748 linear regulator can be set by its internal feedback resistors when the ADJ pin is grounded. In addition, the output voltage of AIC1748

linear regulator can be set by the external feedback resistors when connecting a resistive divider R_1 and R_2 . While connecting a resistive divider, V_{OUT} can be calculated as:

$$V_{\text{OUT}} = 0.8 \times \left(1 + \frac{R_1}{R_2} \right)$$

The resistive divider should sit as close to ADJ pin as possible.

POWER DISSIPATION

The maximum power dissipation of AIC1748 depends on the thermal resistance of its case and circuit board, the temperature difference between the die junction and ambient air, and the rate of airflow. The rate of temperature rise is greatly affected by the mounting pad configuration on the PCB, the board material, and the ambient temperature. When the IC mounting with good thermal conductivity is used, the junction temperature will be low even when large power dissipation applies.

The power dissipation across the device is

$$P = I_{\text{OUT}} (V_{\text{IN}} - V_{\text{OUT}})$$

The maximum power dissipation is:

$$P_{\text{MAX}} = \frac{(T_{\text{J-max}} - T_{\text{A}})}{R\theta_{\text{JA}}}$$

Where $T_{\text{J-max}}$ is the maximum allowable junction temperature (150 $^\circ\text{C}$), and T_{A} is the ambient temperature suitable in application.

As a general rule, the lower temperature is, the better reliability of the device is. So the PCB mounting pad should provide maximum thermal conductivity to maintain low device temperature.

■ PHYSICAL DIMENSIONS

● SOT-23 PACKAGE OUTLINE DRAWING

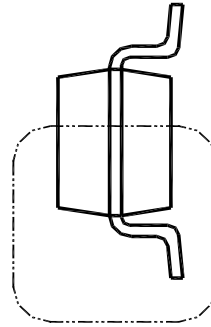
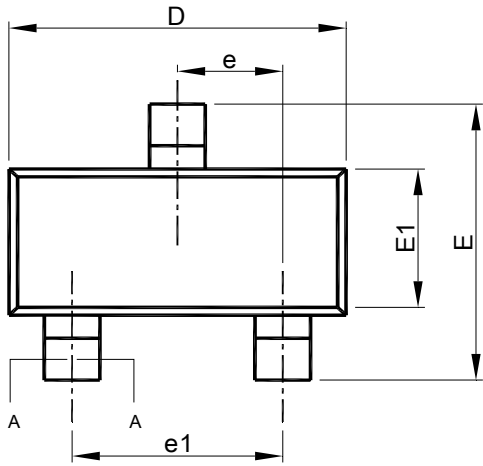

SEE VIEW B

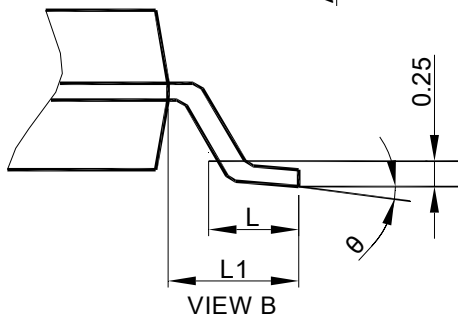
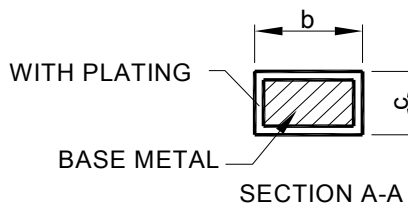
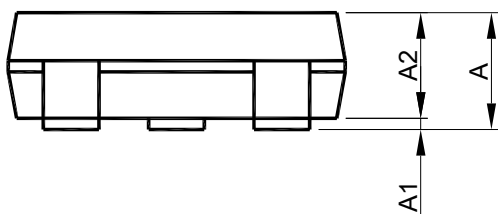

GAUGE PLANE
SEATING PLANE

SYMBOL	SOT-23	
	MILLIMETERS	
	MIN.	MAX.
A	0.95	1.45
A1	0.05	0.15
A2	0.90	1.30
b	0.30	0.50
c	0.08	0.22
D	2.80	3.00
E	2.60	3.00
E1	1.50	1.70
e	0.95 BSC	
e1	1.90 BSC	
L	0.30	0.60
L1	0.60 REF	
θ	0°	8°

- Note: 1. Refer to JEDEC MO-178.
 2. Dimension "D" does not include mold flash, protrusions or gate burrs. Mold flash, protrusion or gate burrs shall not exceed 10 mil per side.
 3. Dimension "E1" does not include inter-lead flash or protrusions.
 4. Controlling dimension is millimeter, converted inch dimensions are not necessarily exact.

● SOT-23-5 PACKAGE OUTLINE DRAWING

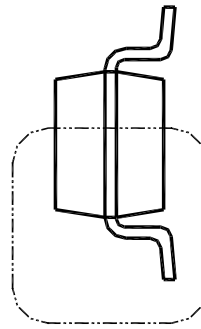
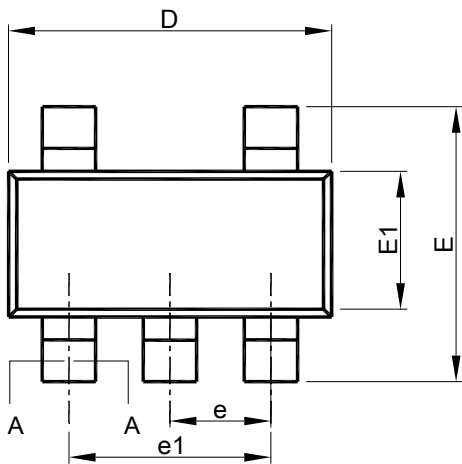

SEE VIEW B

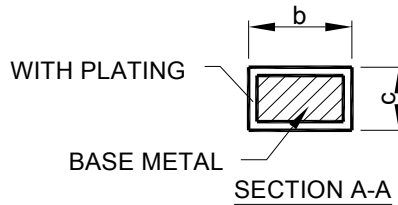
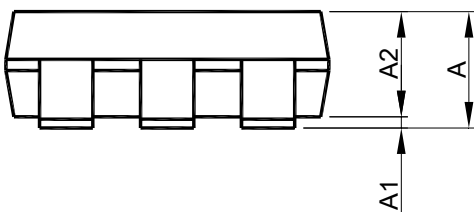

SECTION A-A

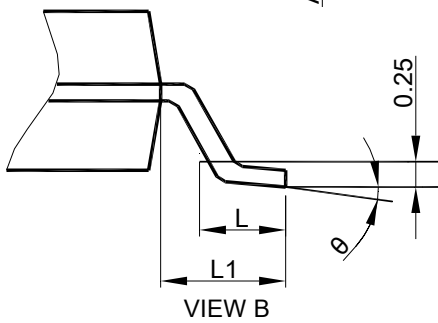

GAUGE PLANE
SEATING PLANE

VIEW B

Note : 1. Refer to JEDEC MO-178AA.

2. Dimension "D" does not include mold flash, protrusions or gate burrs. Mold flash, protrusion or gate burrs shall not exceed 10 mil per side.
3. Dimension "E1" does not include inter-lead flash or protrusions.
4. Controlling dimension is millimeter, converted inch dimensions are not necessarily exact.

SYMBOL	SOT-23-5	
	MILLIMETERS	
	MIN.	MAX.
A	0.95	1.45
A1	0.05	0.15
A2	0.90	1.30
b	0.30	0.50
c	0.08	0.22
D	2.80	3.00
E	2.60	3.00
E1	1.50	1.70
e	0.95 BSC	
e1	1.90 BSC	
L	0.30	0.60
L1	0.60 REF	
q	0°	8°

● SOT-223 PACKAGE OUTLINE DRAWING

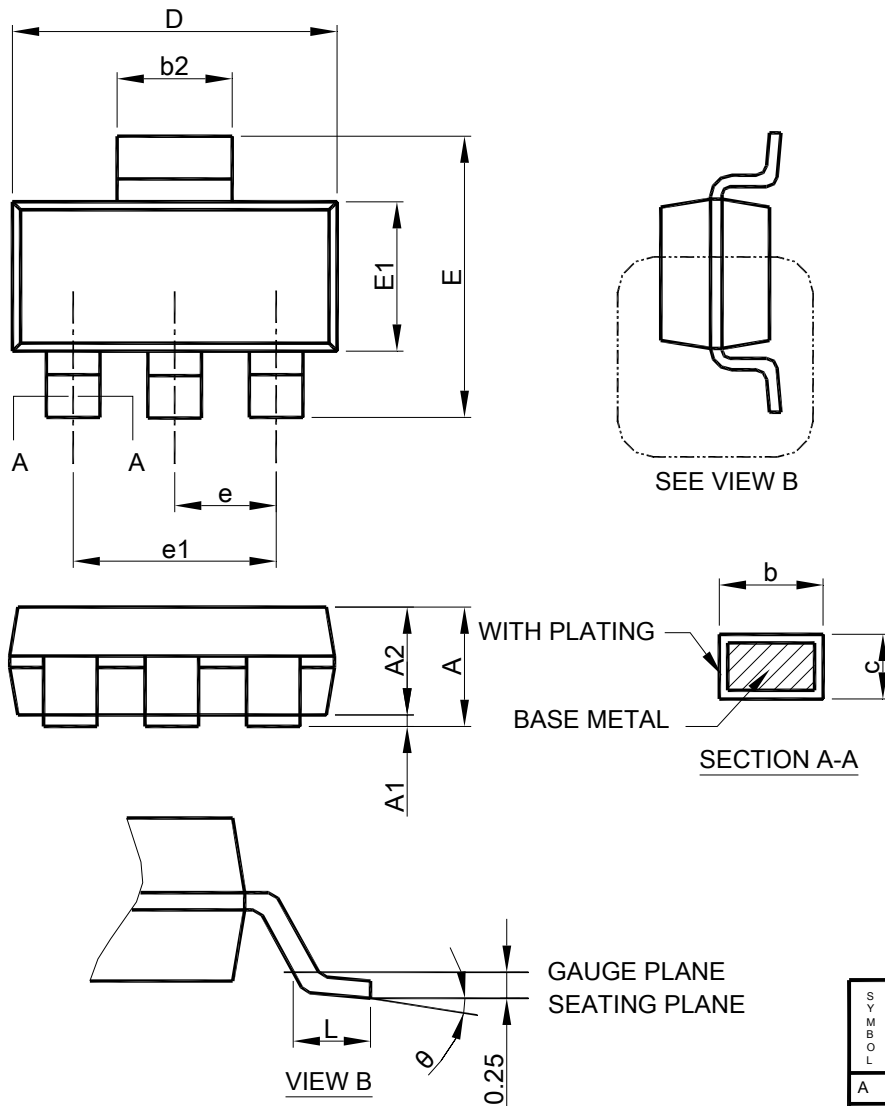

- Note: 1. Refer to JEDEC TO-261AA.
 2. Dimension "D" does not include mold flash, protrusions or gate burrs. Mold flash, protrusion or gate burrs shall not exceed 6 mil per side .
 3. Dimension "E1" does not include inter-lead flash or protrusions.
 4. Controlling dimension is millimeter, converted inch dimensions are not necessarily exact.

SYMBOL	SOT-223	
	MILLIMETERS	
	MIN.	MAX.
A		1.80
A1	0.02	0.10
A2	1.55	1.65
b	0.66	0.84
b2	2.90	3.10
c	0.23	0.33
D	6.30	6.70
E	6.70	7.30
E1	3.30	3.70
e	2.30 BSC	
e1	4.60 BSC	
L	0.90	
θ	0°	8°

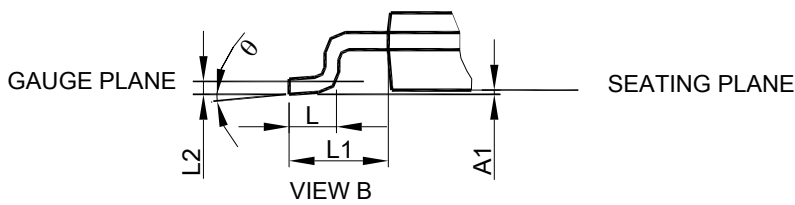
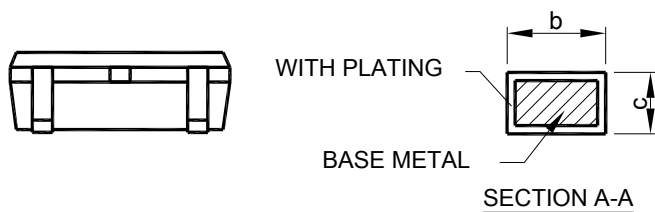
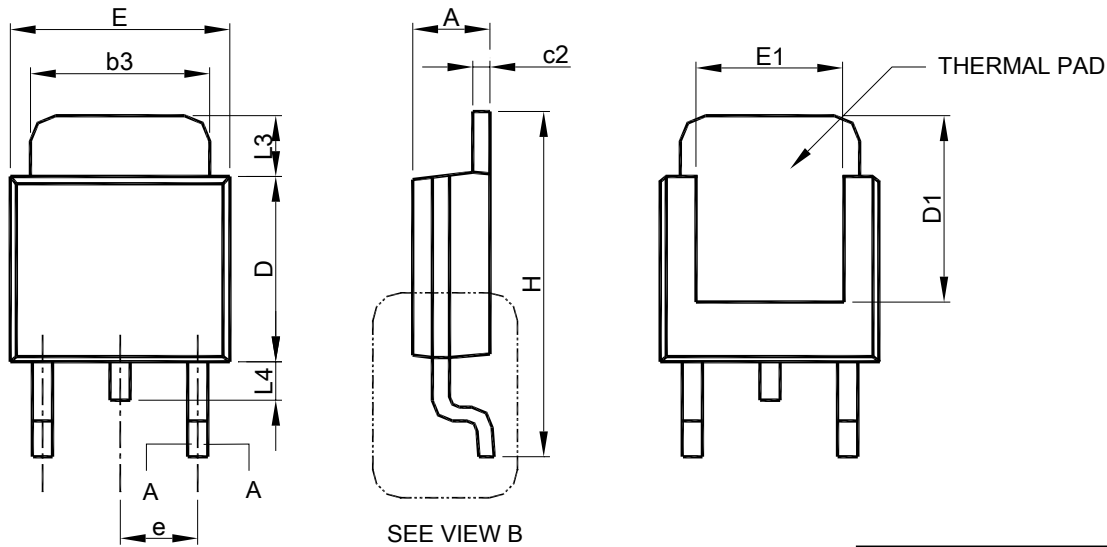
TO-252-3L PACKAGE OUTLINE DRAWING

SYMBOL	TO-252-3L	
	MILLIMETERS	
	MIN.	MAX.
A	2.19	2.38
A1	0.00	0.13
b	0.64	0.89
b3	4.95	5.46
c	0.46	0.61
c2	0.46	0.89
D	5.33	6.22
D1	4.60	6.00
E	6.35	6.73
E1	3.90	5.46
e	2.28 BSC	
H	9.40	10.41
L	1.40	1.78
L1	2.67 REF	
L2	0.51 BSC	
L3	0.89	2.03
L4	--	1.02
θ	0°	8°

- Note: 1. Refer to JEDEC TO-252AA and AB.
 2. Dimension "E" does not include mold flash, protrusions or gate burrs. Mold flash, protrusion or gate burrs shall not exceed 6 mil per side .
 3. Dimension "D" does not include inter-lead flash or protrusions.
 4. Controlling dimension is millimeter, converted inch dimensions are not necessarily exact.

● TO-252-5L PACKAGE OUTLINE DRAWING

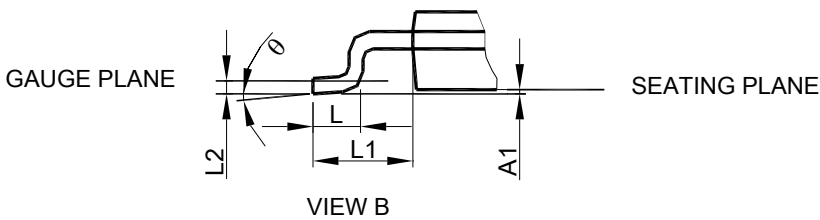
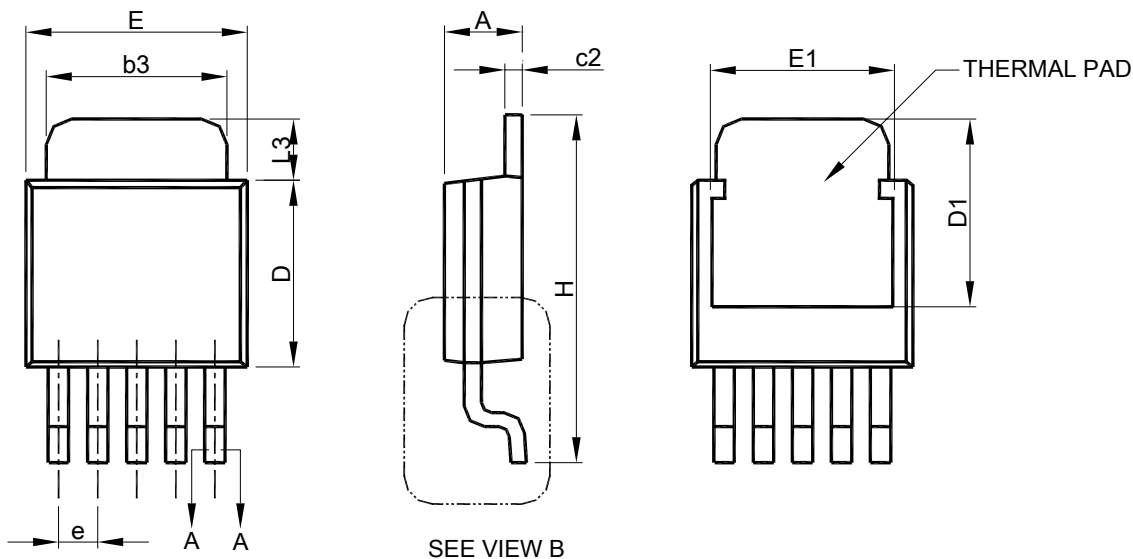

SYMBOL	TO-252-5L	
	MILLIMETERS	
	MIN.	MAX.
A	2.19	2.38
A1	0.00	0.13
b	0.51	0.71
b3	4.32	5.46
c	0.46	0.61
c2	0.46	0.89
D	5.33	6.22
D1	4.90	6.00
E	6.35	6.73
E1	4.32	5.33
e	1.27 BSC	
H	9.40	10.41
L	1.40	1.78
L1	2.67 REF	
L2	0.51 BSC	
L3	0.89	2.03
q	0°	8°

- Note: 1. Refer to JEDEC TO-252AD and AB.
 2. Dimension "E" does not include mold flash, protrusions or gate burrs. Mold flash, protrusion or gate burrs shall not exceed 6 mil per side .
 3. Dimension "D" does not include inter-lead flash or protrusions.
 4. Controlling dimension is millimeter, converted inch dimensions are not necessarily exact.

● SOT-89 PACKAGE OUTLINE DRAWING

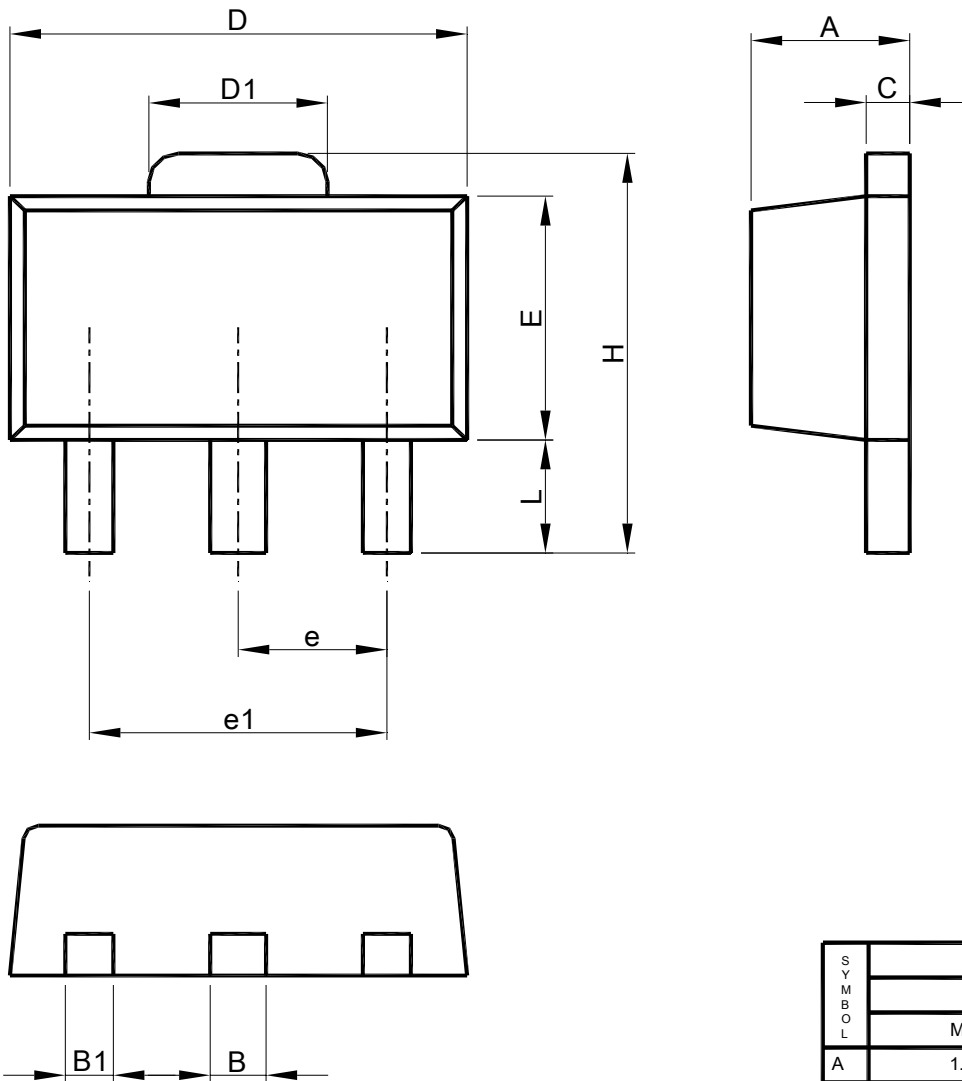

- Note: 1. Refer to JEDEC TO-243AA.
 2. Dimension "D" does not include mold flash, protrusions or gate burrs. Mold flash, protrusion or gate burrs shall not exceed 6 mil per side.
 3. Dimension "E" does not include inter-lead flash or protrusions.
 4. Controlling dimension is millimeter, converted inch dimensions are not necessarily exact.

SYMBOL	SOT-89	
	MILLIMETERS	
	MIN.	MAX.
A	1.40	1.60
B	0.44	0.56
B1	0.36	0.48
C	0.35	0.44
D	4.40	4.60
D1	1.50	1.83
E	2.29	2.60
e	1.50 BSC	
e1	3.00 BSC	
H	3.94	4.25
L	0.89	1.20

● SOT-89-5 PACKAGE OUTLINE DRAWING

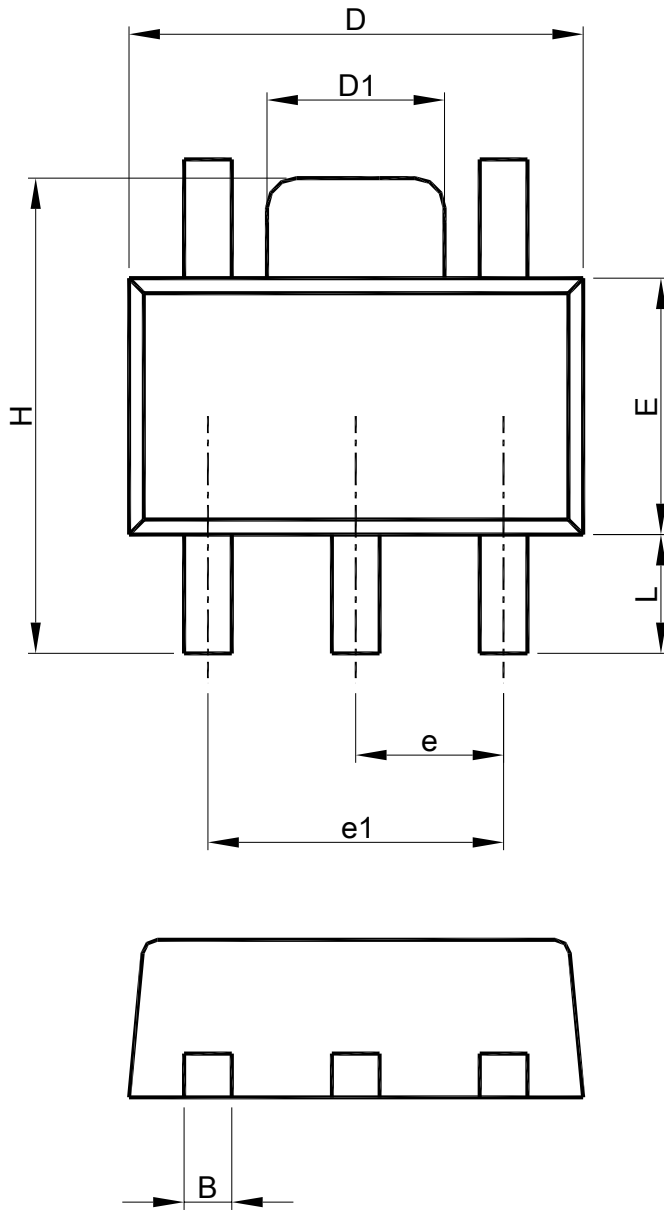

SYMBOL	SOT-89-5	
	MILLIMETERS	
	MIN.	MAX.
A	1.40	1.60
B	0.36	0.56
C	0.35	0.44
D	4.40	4.60
D1	1.50	1.83
E	2.29	2.60
e	1.50 BSC	
e1	3.00 BSC	
H	3.94	4.25
L	0.80	1.20

- Note: 1. Refer to JEDEC TO-243AA.
 2. Dimension "D" does not include mold flash, protrusions or gate burrs. Mold flash, protrusion or gate burrs shall not exceed 6 mil per side.
 3. Dimension "E" does not include inter-lead flash or protrusions.
 4. Controlling dimension is millimeter, converted inch dimensions are not necessarily exact.

Note:

Information provided by AIC is believed to be accurate and reliable. However, we cannot assume responsibility for use of any circuitry other than circuitry entirely embodied in an AIC product; nor for any infringement of patents or other rights of third parties that may result from its use. We reserve the right to change the circuitry and specifications without notice.

Life Support Policy: AIC does not authorize any AIC product for use in life support devices and/or systems. Life support devices or systems are devices or systems which, (i) are intended for surgical implant into the body or (ii) support or sustain life, and whose failure to perform, when properly used in accordance with instructions for use provided in the labeling, can be reasonably expected to result in a significant injury to the user.